

# Cautions for Use

## SAFETY WARNINGS

- Do not use the product under conditions that exceed the range of its specifications. It may cause overheating, smoke, or fire.
- Do not touch the recharging unit while the power is on. There is a danger of electrical shock. Be sure to turn off the power when performing mounting, maintenance, or repair operations on the relay (including connecting parts such as the terminal board and socket).

- Check the connection diagrams in the catalog and be sure to connect the terminals correctly. Erroneous connections could lead to unexpected operating errors, overheating, or fire.

## Cautions for Use

### 1. Regarding output noise surge protection

#### (1) AC Output Type

A high noise surge voltage applied to the SSR load circuit can cause malfunction or permanent damage to the device. If such a high surge is anticipated, use a varistor across the SSR output.

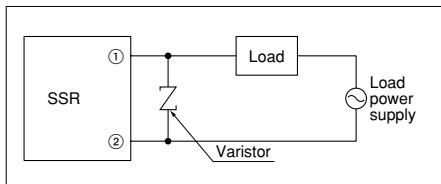

Note: AQ-F solid-state relay output terminals are numbered (8) and (12).

#### (2) DC Output Type

When the SSR is loaded with an inductive load, such as a solenoid contactor, motor, or solenoid valve, use a counter-EMF suppression diode across the load.

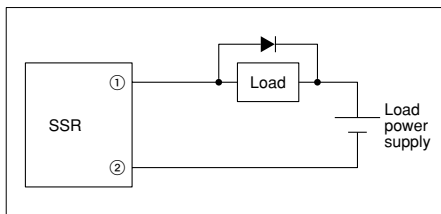

### 2. When used for the load less than rated

An SSR may malfunction if it is used below the specified load. In such an event, use a dummy resistor in parallel with the load.

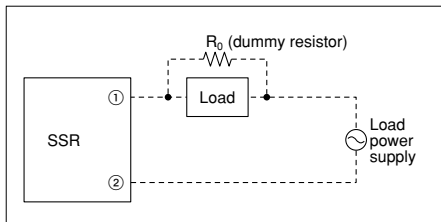

### Load Specifications

Type	Load current
All AQ-G models	20 mA
AQ-E AC output type DC output type	20 mA 1 mA
All AQ-R models	100 mA
All AQ-N models	100 mA
All AQ-K models	100 mA
AQ-F AC output type DC output type	50 mA 5 mA
AQ-B 100 V type 200 V type	10 mA 20 mA
AQ-C 100 V type with AC output 200 V type with AC output DC output type	10 mA 20 mA 1 mA
AQ1 AC output type DC output type	50 mA 5 mA
AQ8 100 V type 200 V type	25 mA 50 mA
I/O relays AC output module DC output module	50 mA 5 mA

### 3. Noise and surge protection at the input side

A high noise surge voltage applied to the SSR input circuit can cause malfunction or permanent damage to the device. If such a high surge is anticipated, use C or R noise absorber in the input circuit.

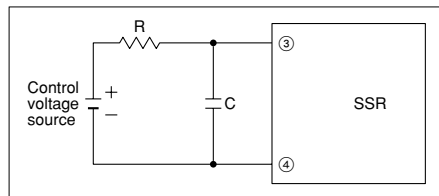

### 4. When the input terminals are connected with reverse polarity

Type	If the polarity of the input control voltage is reversed
AQ1 I/O relay AQ-F AQ-K AQ-N	Reversing the polarity will not cause damage to the device, due to the presence of a protection diode, but the device will not operate.
AQ-G AQ-E AQ8 AQ-B AQ-R AQ-C AQ-H	Reversing the polarity may cause permanent damage to the device. Take special care to avoid polarity reversal or use a protection diode in the input circuit.

### 5. In the case of operating voltage containing ripple

If the SSR control voltage contains ripple, the peak of the ripple should not exceed the maximum rated control voltage, and the bottom of the ripple should exceed the minimum rated control voltage.

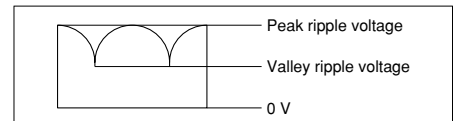

### 6. Cleaning solvents compatibility

Dip cleaning with an organic solvent is recommended for removal of solder flux, dust, etc. Select a cleaning solvent from the following table. If ultrasonic cleaning must be used, the severity of factors such as frequency, output power and cleaning solvent selected may cause loose wires and other defects. Make sure these conditions are correct before use. For details, please consult us.

Cleaning solvent	Compatibility (○: Yes ×: No)
Chlorine-base • Trichlene • Chloroethylene	○
Aqueous • Indusco • Hollis • Lonco Terg	○
Alcohol-base • IPA • Ethanol	○
Others • Thinner • Gasoline	×

### 7. Others

(1) If an SSR is used in close proximity to another SSR or heat-generating device, its ambient temperature may exceed the allowable level. Carefully plan SSR layout and ventilation.

(2) Soldering to SSR terminals should be completed within 5 seconds at 260°C.

(3) Terminal connections should be made by referring to the associated wiring diagram.

(4) For higher reliability, check device quality under actual operating conditions.

## Snubber Circuit

### 1. Reduce dv/dt

An SSR used with an inductive load can accidentally fire due to a high load voltage rise rate (dv/dt), even though the load voltage is below the allowable level (inductive load firing).

Our SSRs contain a snubber circuit designed to reduce dv/dt.

### 2. Selecting the snubber constants

#### 1) C selection

The charging coefficient tau for C of the SSR circuit is shown in formula ①

$$\tau = (R_L + R) \times C \text{ ----- ①}$$

By setting formula ① so that it is below dv/dt value you have:

$$C \frac{\tau}{(R_L + R)} = \frac{0.632V_A}{(dv/dt) \times (R_L + R)} \text{ ----- ②}$$

By setting C = 0.1 to 0.2 μF, dv/dt can be controlled to between nV/μs and n+V/μs or lower. For the condenser, use either an MP condenser metallized polyester film. For the 100 V line, use a voltage between 250 and 400 V, and for the 200 V line, use a voltage between 400 and 600 V.

# Cautions for Use

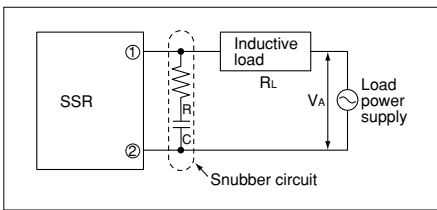

## 2) R selection

If there is no resistance R (the resistance R controls the discharge current from condenser C), at turn-on of the SSR, there will be a sharp rise in  $dv/dt$  and the high peak value discharge current will begin to flow. This may cause damage to the internal elements of the SSR. Therefore, it is

always necessary to insert a resistance R. In normal applications, for the 100 V line, have  $R = 10$  to  $100 \Omega$  and for the 200 V line, have  $R = 20$  to  $100 \Omega$ . (The allowable discharge current at turn-on will differ depending on the internal elements of the SSR.) The power loss from R, written as P, caused by the discharge current and charging current from C, is shown in formula ③ below. For the 100 V line, use a power of 1/2 W, and for the 200 V line, use a power above 2 W.

$$P = \frac{C \times V_A^2 \times f}{2} \text{ ----- ③}$$

f = Power supply frequency

Also, at turn-off of the SSR, a ringing circuit is formed with the capacitor C and the circuit inductance L, and a spike voltage is generated at both terminals of the SSR. The resistance R serves as a control resistance to prevent this ringing. Moreover, a good non-inductive resistance for R is required. Carbon film resistors or metal film resistors are often used.

For general applications, the recommended values are  $C = 0.1 \mu F$  and  $R = 20$  to  $100 \Omega$ . There are cases of resonance in the inductive load, so the appropriate care must be taken when making your selections.

## Thermal Design

SSRs used in high-reliability equipment require careful thermal design. In particular, junction temperature control has a significant effect on device function and life time. The rated load current for board-mounting SSRs is defined as the maximum current allowable at an ambient temperature of  $40^\circ C$  ( $30^\circ C$ ) and under natural cooling. If the ambient temperature exceeds  $40^\circ C$  ( $30^\circ C$ ), load current derating is necessary according to the load current versus ambient temperature curve. If adjacent devices act as

heat sources, the SSR should be located more than 10 mm away from those devices. SSRs with a 5 A rating or more must be used with the dedicated heat sinks listed in Table 1 or equivalents. To ensure adequate thermal conduction, apply thermal conductive compound (Toshiba silicone YG6111, TSK5303 or alternate) to the SSR's mounting surface. For information on external heat sinks for our SSRs and their mounting method, refer to "Data and Cautions for Use for respective relay".

Table 1. Dedicated on-board heat sinks

Load current	Type	Heat sink
5 A	AQ5A2-ZP3/28V DC	AQ-HS-5A
10 A	AQ-R (10 to 20A)	AQP-HS-20A
	AQ-N (10 to 20A)	
15 A	AQ-R (10 to 20A)	AQP-HS-20A
	AQ-N (10 to 20A)	
20 A	AQ-R (10 to 20A)	AQP-HS-20A
	AQ-N (10 to 20A)	
25 A	AQ-N (25A)	AQP-HS-30/40A
40 A	AQ-R (40A)	
40 A	AQ-N (40A)	

## Protection Circuit

High-reliability SSR circuits require an adequate protection circuit, as well as careful study of the characteristics and maximum ratings of the device.

### 1. Over-Voltage Protection

The SSR load power supply requires adequate protection against over-voltage errors from various causes. The methods of over-voltage protection include the following:

- (1) Use devices with a guaranteed reverse surge withstand voltage (controlled avalanche devices, etc.)
- (2) Suppress transient spikes  
Use a switching device in the secondary circuit of a transformer or use a switch with a slow opening speed.
- (3) Use a surge absorption circuit  
Use a CR surge absorber or varistor across the load power supply or SSR.

Special care must be taken so power on/off surges or external surges do not exceed the device's rated load voltage. If a surge voltage exceeding the device's rated voltage is anticipated, use a surge absorption device and circuit (e.g. a ZNR from Matsushita Electronic Components). Choosing the Rated Voltage of the ZNR

- (1) Peak supply voltage
- (2) Supply voltage variation
- (3) Degradation of ZNR characteristic ( $1 \text{ mA} \pm 10\%$ )
- (4) Tolerance of rated voltage (10%)

For application to 100 V AC lines, choose a ZNR with the following rated voltage:  
 $(1) \times (2) \times (3) \times (4) = (100 \times 2) \times 1.1 \times 1.1 \times 1.1 = 188 \text{ (V)}$

### 2. Over-Current Protection

An SSR circuit operated without over-cur-

rent protection may result in damage to the device. Design the circuit so the device's rated junction temperature is not exceeded for a continuous overload current. (e.g. Surge current into a motor or light bulb)

The surge-on current rating applies to over-current errors which occur less than several tens of times during the service life of a semiconductor device. A protection coordination device is required for this rating. Methods of over-current protection include the following:

- (1) Suppressing over-currents  
Use a current limiting reactor in series with the load power supply.
- (2) Use a current shut-off device  
Use a current limiting fuse or circuit breaker in series with the load power supply.

## Load Type Description

### 1. Heaters (Resistive Load)

The SSR is best suited to resistive loads. Noise levels can be drastically lowered with zero-crossing switching.

### 2. Lamps

Tungsten or halogen lamps draw a high inrush current when turned on (approximately 7 to 8 times the steady-state current for zero-crossing SSRs; approximately 9 to 12 times, in the worst case, for non zero-crossing SSRs). Choose an SSR so the peak of the inrush

current does not exceed 50% of the SSR surge-on current.

### 3. Solenoids

AC-driven solenoid contactors or solenoid valves also draw inrush current when they are activated. Choose an SSR such that the peak of the inrush current does not exceed 50% of the SSR surge-on current. For small solenoid valves and AC relays in particular, a leakage current may cause the load to malfunction after the SSR turns off. In such an event, use a dummy

resistor in parallel with the load.

- Using an SSR below the Specified Load

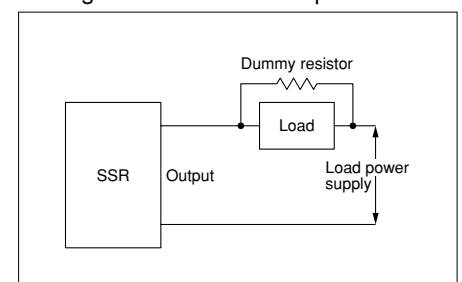

# Cautions for Use

## 4. Motors

When starting, an electric motor draws a symmetrical AC starting current some 5 to 10 times the steady-state load current, superimposed on a DC current. The starting time during which this high starting current is sustained depends on the capacities of the load and load power supply. Measure the starting current and time under the motor's actual operating conditions and choose an SSR so the peak of the starting current does not exceed 50% of the SSR surge-on current. When the motor load is deactivated, a voltage exceeding the load supply voltage is applied to the SSR due to counter-EMF. This voltage is approximately 1.3 times the load supply voltage for induction motors, and approximately 2 times that for synchronous motors.

### • Reversible Motor Control

When the direction of motor rotation is reversed, the transient current and time required for the reversal far exceed those required for simple starting. The reversing current and time should also be measured under actual operating conditions. For a capacitor-starting, single-phase in-

duction motor, a capacitive discharge current appears during the reversal process. Be sure to use a current limiting resistor or reactor in series with the SSR. Also, the SSR should have a high marginal voltage rating, since a voltage twice as high as the load supply voltage develops across the SSR in the reversal process. (For reversible control on a 100 V AC line, use SSRs with a 200 V rating; for use on a 200 V AC line, contact your nearest our representative for further information.)

For reversible motor control, carefully design the driver circuit so the forward and reverse SSRs do not turn on at the same time.

Transistor-driven reversible motor control circuit

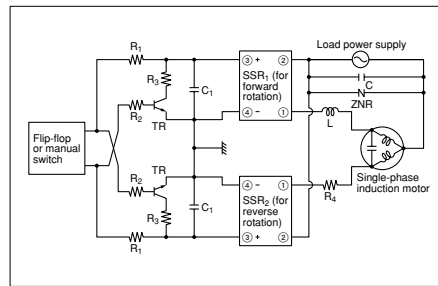

## 5. Capacitive Load

A capacitive load (switching regulator, etc.) draws an inrush current to charge the load capacitor when the SSR turns on. Choose an SSR so the peak of the inrush current does not exceed 50% of the SSR surge-on current. A timing error of up to one cycle can occur when a switch used in series with the SSR is opened or closed. If this is a problem, use an inductor (200 to 500  $\mu$ H) in series to the SSR to suppress dv/dt error.

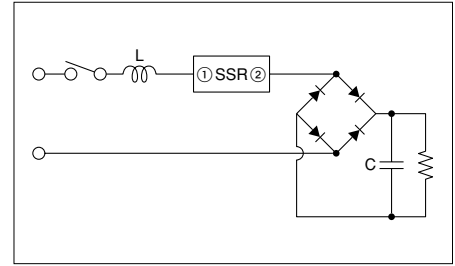

## 6. Other Electronic Equipment

In general, electronic equipment uses line filters in the primary supply circuit.

The capacitors used in the line filters may cause the SSR to malfunction due to dv/dt turn on when the equipment is turned on

or off. In such an event, use an inductor (200 to 500  $\mu$ H) in series with the SSR to suppress dv/dt turn on.

## Load Inrush Current Wave Forms and Timing

(1) Incandescent Lamp Load

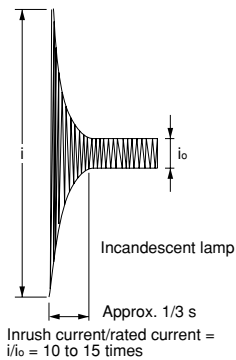

(2) Mercury Lamp Load  $i/i_o = 3$  times

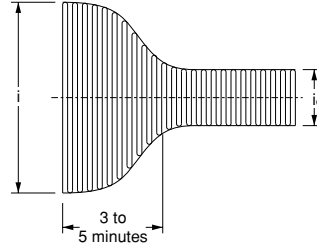

In general, discharge lamp circuits use a combination of a discharge tube, transformer, choke coils, and capacitors. Note that the lamp may draw an inrush current may be 20 to 40 times the steady-state current, especially if the supply impedance is low in the high power factor type.

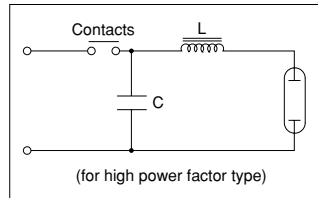

(3) Fluorescent Lamp Load  $i/i_o = 5$  to 10 times

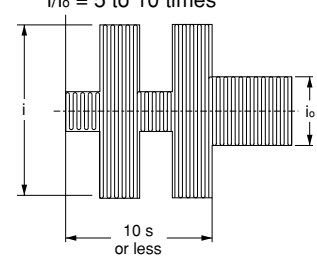

(4) Motor Load  $i/i_o = 5$  to 10 times

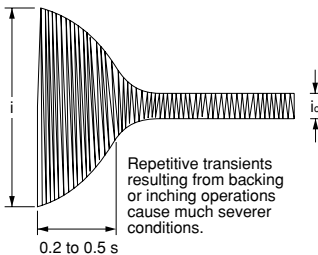

(5) Solenoid Load  $i/i_o = 10$  to 20 times

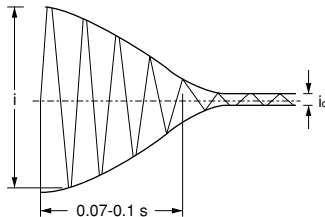

(6) Electromagnetic Contact Load  $i/i_o = 3$  to 10 times

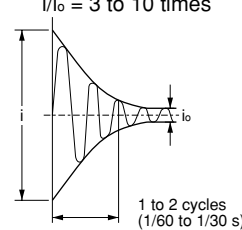

(7) Capacitive Load  $i/i_o = 20$  to 40 times

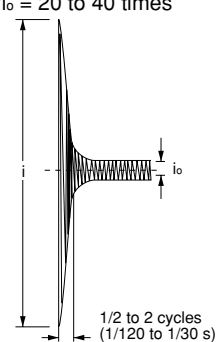

## SSR Driving Circuits

### 1. Relay Driver

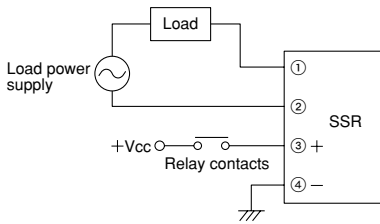

### 2. NPN Transistor Driver

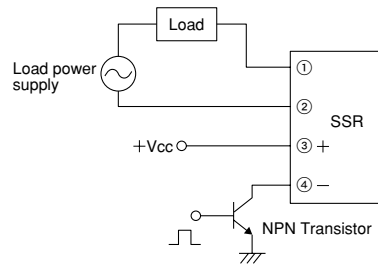

### 3. PNP Transistor Driver

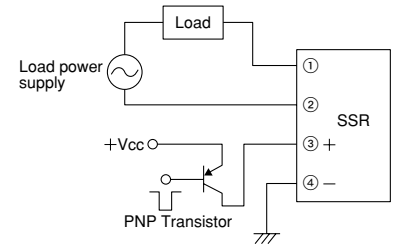

### 4. TTL/DTL/IC Driver

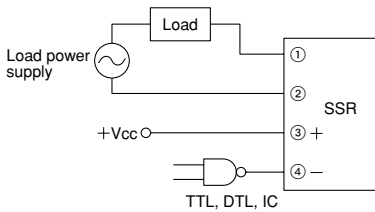

### 5. C-MOS/IC Driver

(1) SSR fires when IC output is HIGH:

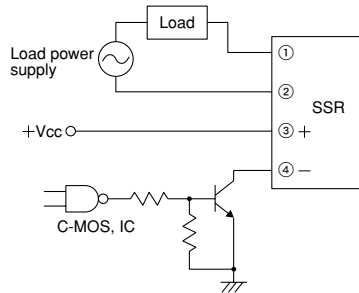

(2) SSR fires when IC output is LOW:

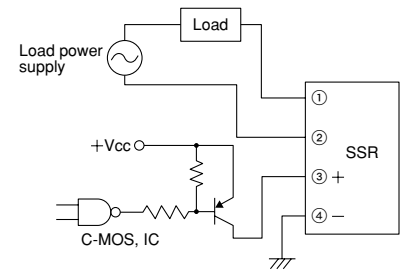

### 6. Self Sustaining Circuit Using SSR

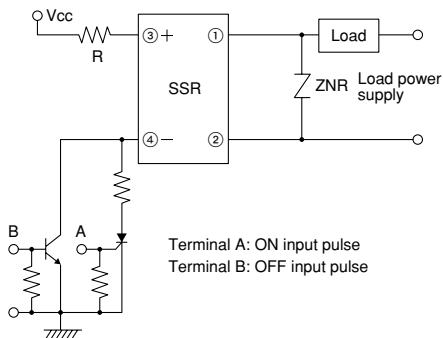

### 7. Driving with a Shared Supply

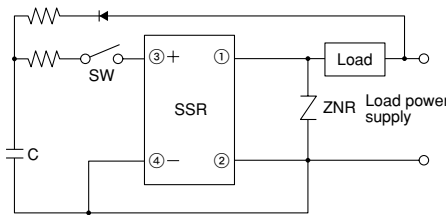

### 8. SSRs Used in Series

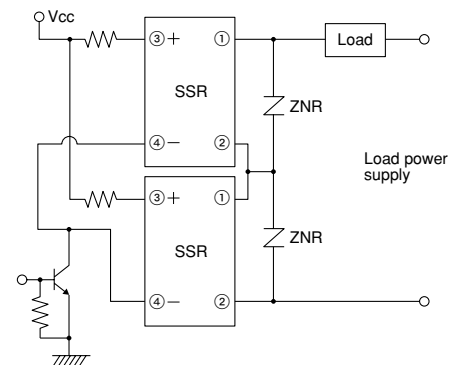

## Phototriac Coupler, AQ-H Solid State Relay Driving Circuits

### 1. NPN Transistor Driver

1) Phototriac Coupler

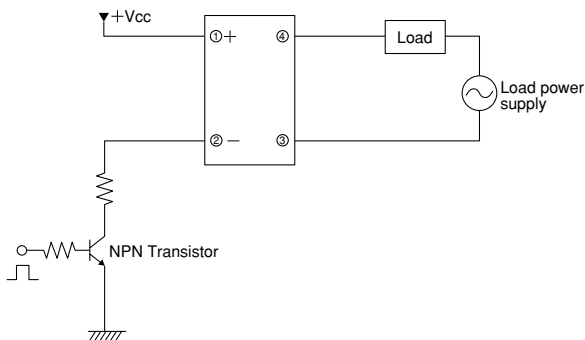

2) AQ-H Solid State Relay

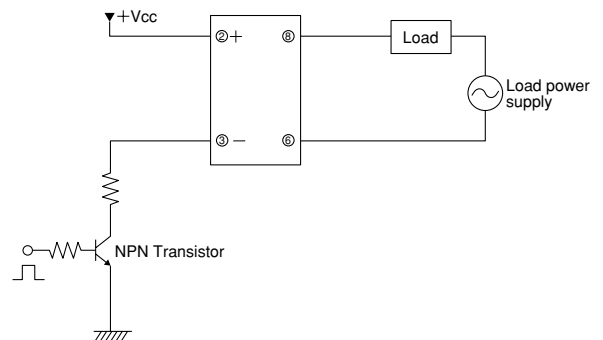

\* Phototriac coupler and AQ-H is current driving type.