

RoHS Directive compatibility information  
<http://www.nais-e.com/>

### FEATURES

- **Small size, Low height**  
 31 mm (L) × 16 mm (W) × 9 mm (H)  
 1.220 inch (L) × .630 inch (W) × .354 inch (H)
- **Low Insertion Loss**  
 Achieved 1dB max. insertion loss (Typ. 0.5dB)
- **Latching Operation**  
 Latching operation is realized by "Original polarized actuator construction"
- **Telcordia GR-1221-CORE comply**

### APPLICATIONS

- OADM
- Protection switching (WDM, CATV, FTTH)
- Network monitoring
- Optical measuring instrument

### ORDERING INFORMATION

AWAP

Switch type	Fiber type & Wavelength			Operation type	Connector type	Nominal coil voltage
	Single mode (9/125/900)	Multi mode (50/125/900)	Multi mode (62.5/125/900)			
0: 1×2 1: 2×2	0: 1,310±20nm 1: 1,550±20nm 2: 1,310/1,550nm±20nm	3: 850±20nm 4: 1,310±20nm 5: 850/1,310nm±20nm	6: 850±20nm 7: 1,310±20nm 8: 850/1,310nm±20nm	1: 1 coil latching 2: 2 coil latching	2: SC/AdPC 3: MU/AdPC 5: FC/AdPC	1: 3V DC 6: 4.5V DC 9: 5V DC

### FORM

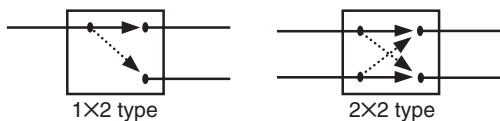

### SPECIFICATIONS

Item	Characteristics	
	Single mode	Multi mode
Insertion loss <sup>Notes) 1</sup>	Max. 1.0 dB	Max. 1.0 dB
Isolation	Min. 60 dB	Min. 50 dB
Return loss <sup>Notes) 1</sup>	Min. 50 dB	Min. 20 dB
P.D.L. <sup>Notes) 1</sup>	Max. 0.1 dB	—
Optical input power	Max. 100 mW (20 dBm)	Max. 100 mW (20 dBm)
Mechanical life (at 180 cpm)	Min. 10 <sup>7</sup>	
Vibration resistance	Functional	10 to 55 Hz at double amplitude of 0.75 mm (Optical power fluctuation: within 20%)
	Destructive	10 to 55 Hz at double amplitude of 1.52 mm
Shock resistance (Half-wave pulse of sine wave: 11 ms)	Functional	Min. 200 m/s <sup>2</sup> (Optical power fluctuation: within 20%)
	Destructive	Min. 500 m/s <sup>2</sup>
Switching time (at 20°C 68°F) <sup>Notes) 2</sup>	Max. 10 ms (applied nominal operating voltage)	
Conditions for operation, transport and storage (Not freezing and condensing at low temperature)	Ambient temperature	−40°C to +70°C −40°F to +158°F
	Humidity	5 to 85% R.H.
Unit weight	Approx. 11 g	

Notes: 1. Connectors are excluded. Add up to 0.2 dB typ. for each connector. Also, connector return loss is approx. 50 dB.

2. Oscilloscope waveform of switching characteristic.

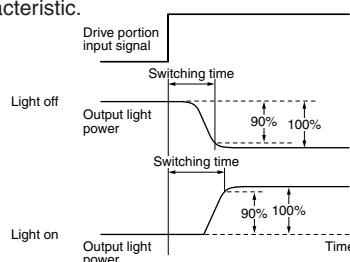

# WA (AWAP)

## COIL DATA (at 20°C 68°F)

<1 coil latching>

Nominal operating voltage (V DC)	3	4.5	5
Nominal operating current (mA)	50	33.3	30
Coil resistance (Ω)	60	135	166.7
Nominal operating power (mW)	150		
Max. allowable voltage	130% V of the nominal voltage		

<2 coil latching>

Nominal operating voltage (V DC)	3	4.5	5
Nominal operating current (mA)	66.7	44.4	40
Coil resistance (Ω)	45	101.3	125
Nominal operating power (mW)	200		
Max. allowable voltage	130% V of the nominal voltage		

\* For operation, more than 20ms pulse with nominal voltage +20%/−5% V is recommended.

## DIMENSIONS

mm inch

1×2

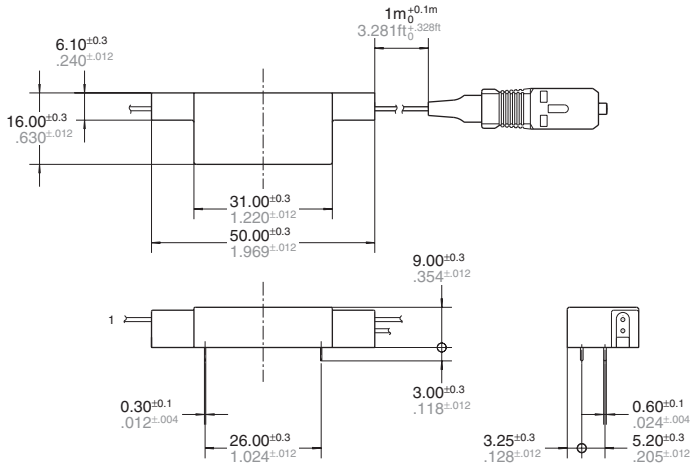

2×2

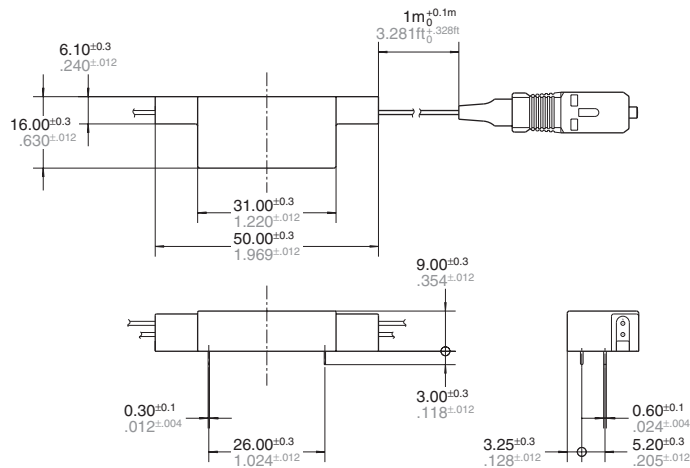

PC board pattern (Tolerance: ±0.1 ±.004)

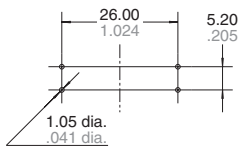

## Optical signal I/O and coil impress direction indication diagram

1×2, 1 coil latching

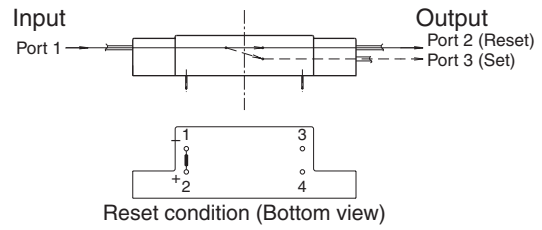

1×2, 2 coil latching

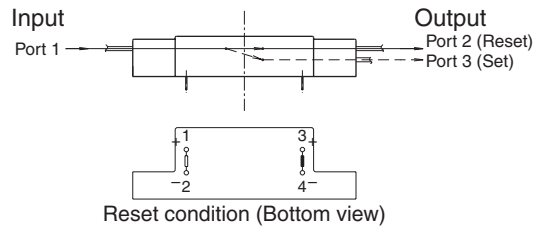

2×2, 1 coil latching

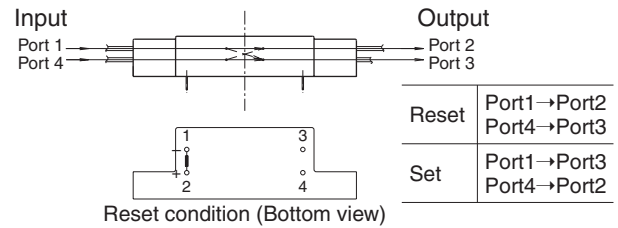

2×2, 2 coil latching

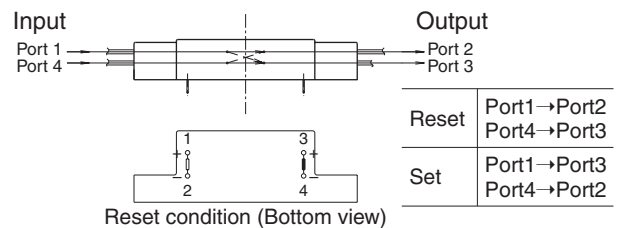

## Coil drive direction (1×2, 2×2)

	Terminal#	1 coil latching	2 coil latching
to SET	1	+V	+V
	2	GND	GND
	3		
	4		
to RESET	1	GND	
	2	+V	
	3		+V
	4		GND

**PERFORMANCE TEST DATA (at 20°C 68°F)****A: Basic characteristic**

Test item	Test target value and condition	Referential standard	Number of samples	Result
1. Set voltage	Less than nominal voltage	JIS C 5442 4.6 Method A	20	Good
2. Reset voltage	Less than nominal voltage	JIS C 5442 4.6 Method A	20	Good
3. Set time	Less than 10ms (without diode)	JIS C5931 5.5	20	Good
4. Reset time	Less than 10ms (without diode)	JIS C5931 5.5	20	Good
5. Insertion loss	Less than 1.0 dB	IEC 61300-2-4 JIS C5901 6.2	20	Good
6. Isolation	More than 60 dB	IEC 61300-3-9 JIS C5901 6.7	20	Good
7. Return loss	More than 50 dB	IEC 61300-3-6 JIS C5901 6.5	20	Good
8. P.D.L.	Less than 0.1 dB	IEC 61300-3-2 JIS C5901 6.3	20	Good

**B: Life tests**

Test item	Test target value and condition	Referential standard	Number of samples	Result
1. Optical input power	100mW, 2 min.	Telcordia GR-1073	6	Good
2. Mechanical life	1 × 10 <sup>7</sup> , 10 Hz (600/min)	JIS C 5442 7.1.2	6	Good

**C: Environmental tests (Mechanical stress)**

Test item	Test target value and condition	Referential standard	Number of samples	Result
1. Vibration resistance	Functional 10 to 55Hz (0.75mm .030inch)	JIS C 5442 5.1	3	Good
	Destructive 10 to 55Hz (1.52mm .060inch)	Telcordia GR-1073	3	Good
2. Shock resistance	Functional 200m/s <sup>2</sup> , sine half-wave pulse 11ms	IEC 61300-2-9 JIS C 5901 7.2	3	Good
	Destructive 500m/s <sup>2</sup> , sine half-wave pulse 11ms	JIS C 5442 5.2	3	Good
3. Cable retention	Tensile strength: 450g 15.873oz, 0.4mm/sec. 1 min.	Telcordia GR-1073	3	Good
4. Side pull	Tensile strength: 230g 8.113oz, at an angle of 90° 5 sec.	Telcordia GR-1073	3	Good

**D: Environmental tests (Temperature & Humidity stress)**

Test item	Test target value and condition	Referential standard	Number of samples	Result
1. Solder heat test	Solder Temp.: 400±5°C 752±41°F Solder Time: 3±0.5 sec.	JIS C 5442 5.5	3	Good
2. High temperature storage	85±2°C 185±35.6°F, 2000 hours	Telcordia GR-1221	11	Good
3. Low temperature storage	-40±2°C -40±35.6°F, 2000 hours	Telcordia GR-1221	11	Good
4. Temperature cycling	-40°C -40°F ↔ 85°C 185°F, 500 cycles	Telcordia GR-1221	11	Good
5. Damp heat	85°C 185°F 85%RH, 1000 hours	Telcordia GR-1221	11	Good
6. Humidity cycle	25°C 77°F 95%RH → 65°C 149°F 95%RH → -10°C 14°F → 25°C 77°F 10 cycles	MIL-STD-202E Method 106 JIS C 5442 6.5	6	Good
7. Compound stress	Random Vibration; 10 to 500 Hz, 98m/s <sup>2</sup> (Ave), 294m/s <sup>2</sup> (Peak) Thermal Shock; -55°C -67°F (30min) ↔ 85°C 185°F (30min) De-energied, 10cyc.	JIS C 5442 6.3	3	Good

# WA (AWAP)

## A-1, 2

### Set voltage and reset voltage

1. Sample: AWAP01226 (1X2 , 1550nm , 4.5VDC coil) n=20

2. Test conditions:

(1) Ambient temperature and humidity: 25°C 77°F, 50 % RH

a) Set voltage

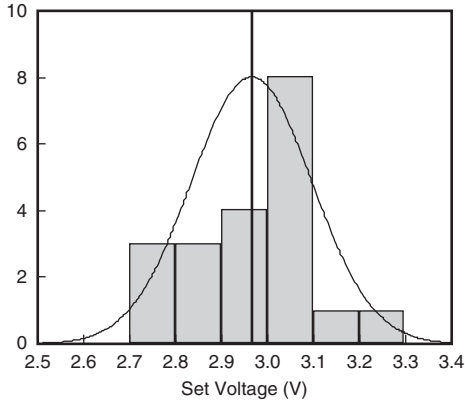

b) Reset voltage

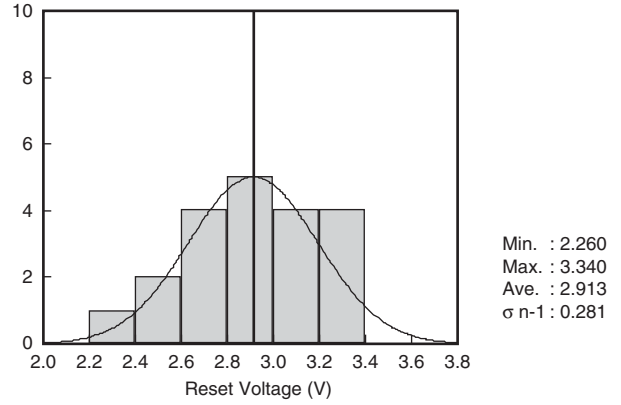

## A-3, 4

### Set time and reset time

1. Sample: AWAP01226 (1X2 , 1550nm , 4.5VDC coil) n=20

2. Test conditions:

(1) Ambient temperature and humidity: 25°C 77°F, 50 % RH

a) Set time

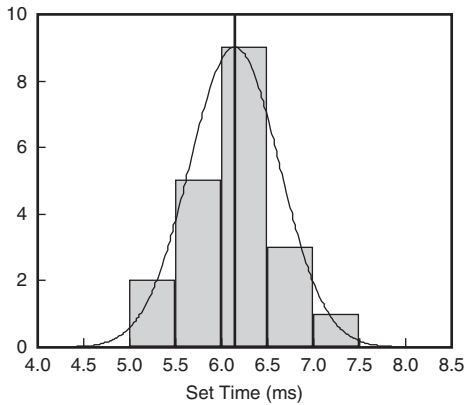

b) Reset time

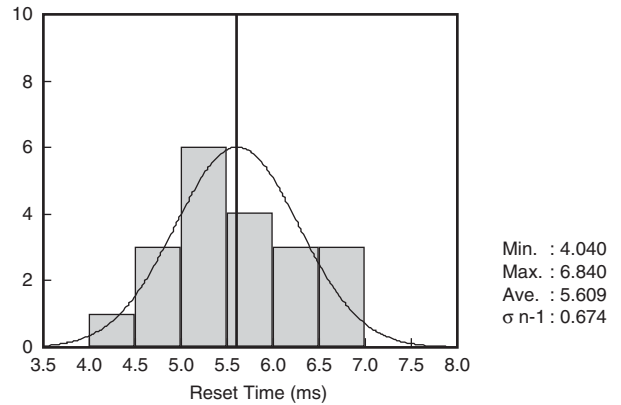

## A-5, 6

### Insertion loss and isolation

1. Sample: AWAP01226 (1X2 , 1550nm , 4.5VDC coil) n=20

2. Test conditions:

(1) Ambient temperature and humidity: 25°C 77°F, 50 % RH

(2) Measuring method see specification sheet;

a) Insertion loss

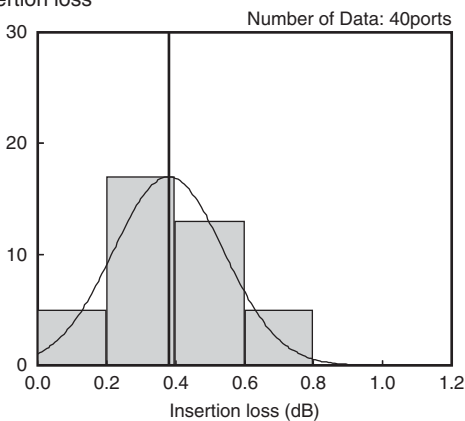

b) Isolation

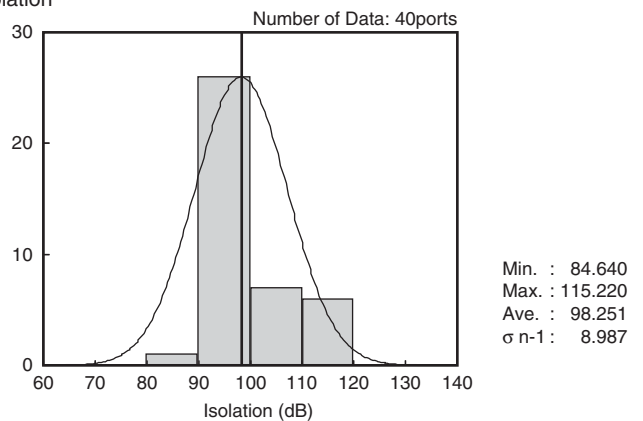

**A-7, 8**

**Return loss and P.D.L.**

- Sample: AWAP01226 (1X2 , 1550nm , 4.5VDC coil) n=20
- Test conditions:
  - Ambient temperature and humidity: 25°C 77°F, 50 % RH
  - Measuring method see specification sheet;

a) Return loss

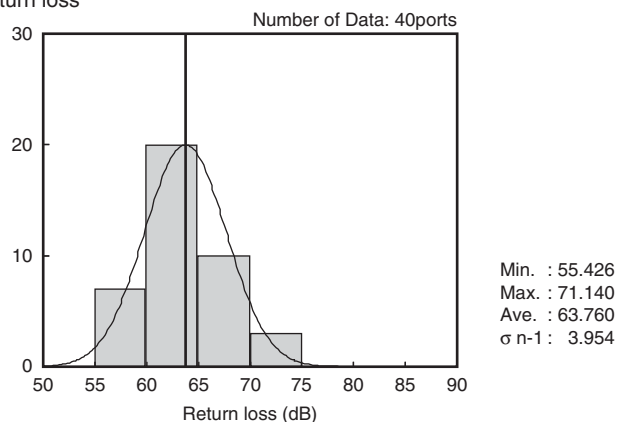

b) P.D.L.

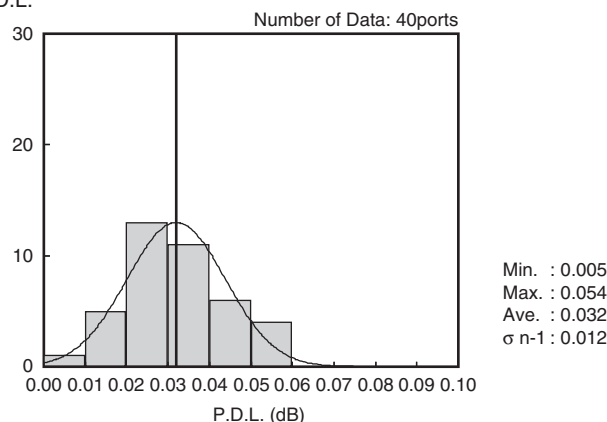

**B-1**

**Optical input power**

- Sample: AWAP01226 (1X2 , 1550nm , 4.5VDC coil) n=6
- Test conditions:
  - Optical input power ; 100 mW
  - Testing time ; 2 min.
- Test results:  
No abnormality was observed for all samples after test.

**B-2**

**Mechanical life test**

- Sample: AWAP01226 (1X2 , 1550nm , 4.5VDC coil) n=6
- Test conditions:
  - Coil voltage ; 4.5VDC (Nominal voltage)
  - Cycle Rate ; 10 Hz (On:OFF=0.05s:0.05s)
  - Ambient temperature and humidity ; 25°C 77°F, 50 % RH
  - Number of operations ;  $1 \times 10^7$  operations
- Test results:  
No abnormality was observed for all samples after  $1 \times 10^7$  operations.

**C-1**

**Vibration resistance test (Functional)**

- Sample: AWAP01226 (1X2 , 1550nm , 4.5VDC coil) n=3
- Test conditions:
  - Frequency ; 10 to 55 Hz
  - Double amplitude ; 0.75 mm .030 inch
  - Coil ; De-energized
  - Detection level ; Optical power change : less than 1 dB
  - Vibration application directions ; 2 hours each against 3 directions
- Test results:  
No abnormality was observed after test.

**C-2**

**Mechanical shock test (Functional)**

- Sample: AWAP01226 (1X2 , 1550nm , 4.5VDC coil) n=3
- Test conditions:
  - Peak acceleration ; 200 m/s<sup>2</sup>
  - Corresponding duration of the pulse ; 11 ms
  - Number of shock applications ; 5 times each
  - Coil ; De-energized
  - Detection level ; Optical power change : less than 1 dB
  - Shock application directions ; 6 directions
- Test results:  
No abnormality was observed after test.

**(Destructive)**

- Sample: AWAP01226 (1X2 , 1550nm , 4.5VDC coil) n=3
- Test conditions:
  - Frequency ; 10 to 55 Hz
  - Double amplitude ; 1.52 mm .060 inch
  - Coil ; De-energized
  - Vibration application directions ; 2 hours each against 3 directions
- Test results:  
No abnormality was observed after test.

**(Destructive)**

- Sample: AWAP01226 (1X2 , 1550nm , 4.5VDC coil) n=3
- Test conditions:
  - Peak acceleration ; 500 m/s<sup>2</sup>
  - Corresponding duration of the pulse ; 11 ms
  - Number of shock applications ; 5 times each
  - Coil ; De-energized
  - Shock application directions ; 6 directions
- Test results:  
No abnormality was observed after test.

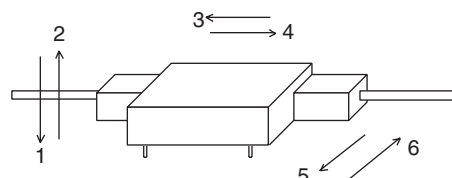
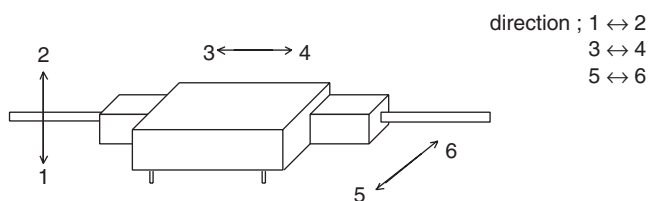

# WA (AWAP)

## C-3

### Cable retention

1. Sample: AWAP01226 (1X2, 1550nm, 4.5VDC coil) n=3

#### 2. Test conditions:

- (1) Tensile strength ; 450g 15.873oz
- (2) Rate ; 0.4mm .016inch/sec.
- (3) The testing time ; 1 min.
- (4) Coil ; De-energized
- (5) Check item ; Physical damage and optical characteristic
- (6) Tensile application directions

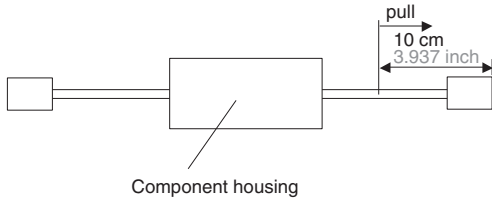

#### 3. Test results:

No abnormality was observed after test.

## C-4

### Cable side pull

1. Sample: AWAP01226 (1X2, 1550nm, 4.5VDC coil) n=3

#### 2. Test conditions:

- (1) Tensile strength ; 230g 8.113oz
- (2) Angle ; 90°
- (3) The time applied ; 5 sec.
- (4) Check item ; Physical damage and optical characteristic  
Measure the insertion loss after the load is applied for at least 5 seconds.  
Remove the load, and after 10 seconds remeasure the loss.
- (5) Tensile application directions

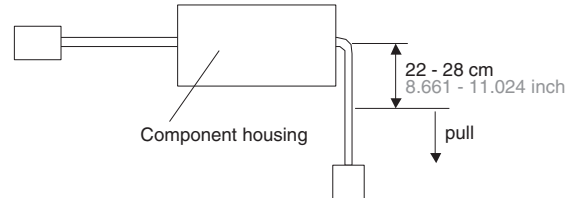

#### 3. Test results:

No abnormality was observed after test.

## D-1

### Solder heat test

1. Sample: AWAP01226 (1X2, 1550nm, 4.5VDC coil) n=3

#### 2. Test conditions:

- (1) Solder temperature ;  $400 \pm 5^\circ\text{C}$   $752 \pm 41^\circ\text{F}$
- (2) Soldering time ;  $3 \pm 0.5$  S
- (3) Solder ; Sn 96.5%, Ag 3%, Cu 0.5%
- (4) Test method ; Switch terminals are inserted into double sided through-hole PCB.  
Each terminal is applied heat stress by soldering iron.

#### 3. Test results:

No abnormality was observed for all samples after the test.

## D-2

### High temperature storage

1. Sample: AWAP01226 (1X2, 1550nm, 4.5VDC coil) n=11

#### 2. Test conditions:

- (1) Ambient temperature ;  $85 \pm 2^\circ\text{C}$   $185 \pm 35.6^\circ\text{F}$
- (2) Exposure period ; 2000 hours

#### 3. Test results:

No abnormality was observed for all samples after 2000 hours.

## D-3

### Low temperature storage

1. Sample: AWAP01226 (1X2, 1550nm, 4.5VDC coil) n=11

#### 2. Test conditions:

- (1) Ambient temperature ;  $-40 \pm 2^\circ\text{C}$   $-40 \pm 35.6^\circ\text{F}$
- (2) Exposure period ; 2000 hours

#### 3. Test results:

No abnormality was observed for all samples after 2000 hours.

## D-4

### Temperature cycle

1. Sample: AWAP01226 (1X2, 1550nm, 4.5VDC coil) n=11

#### 2. Test conditions:

- (1) Low temperature ;  $-40^\circ\text{C}$   $-40^\circ\text{F}$
- (2) High temperature ;  $85^\circ\text{C}$   $185^\circ\text{F}$
- (3) Number of cycles ; 500 cycles
- (4) Coil ; De-energized

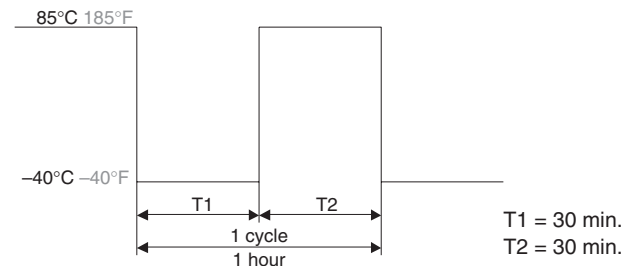

#### 3. Test results:

No abnormality was observed after 500 cycles.

**D-5**

**Damp heat**

1. Sample: AWAP01226 (1×2 , 1550nm , 4.5VDC coil) n=11

2. Test conditions:

- (1) Ambient Temperature ; 85°C 185°F
- (2) Ambient Humidity ; 85 % RH
- (3) Exposure period ; 1000 hours

3. Test results:

No abnormality was observed for all samples after 1000 hours.

**D-6**

**Humidity cycle**

1. Sample: AWAP01226 (1×2 , 1550nm , 4.5VDC coil) n=6

2. Test conditions:

- (1) Number of cycles ; 10 cycles
- (2) Coil ; De-energized

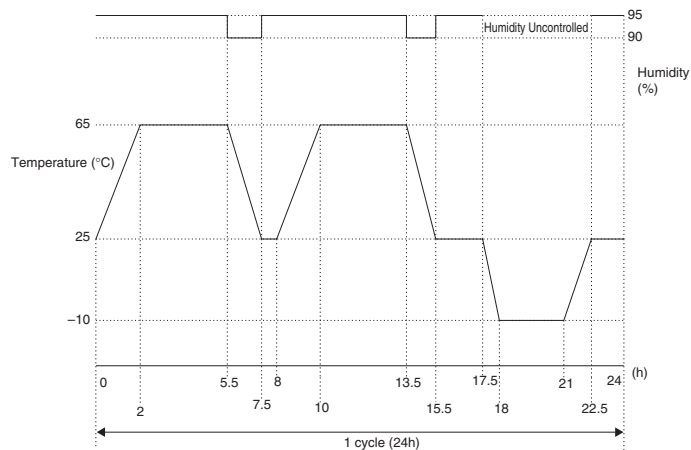

3. Test results:

No abnormality was observed after 100 cycles.

**D-7**

**Compound stress test**

1. Sample: AWAP01226 (1×2 , 1550nm , 4.5VDC coil) n=3

2. Test conditions:

A) Mechanical vibration

- (1) Frequency ; 10 to 500 Hz
- (2) Acceleration ; 98 m/s<sup>2</sup> (Average), 294 m/s<sup>2</sup> (Peak)
- (3) Coil ; De-energized

B) Thermal shock

- (1) Low temperature ; -55°C -67°F
- (2) High temperature ; 85°C 185°F
- (3) Number of cycles ; 10 cycles
- (4) Coil ; De-energized

Remark) Vibration is continuously applied during the thermal shock test.  
Samples are subjected the test under package condition.

3. Test results:

No abnormality was observed after test.

**For Cautions for Use, see Relay Technical Information.**