

FEATURES

- **Low profile**
<Height>
PC board terminal type:
9.5 mm .374 inch
Surface-mount terminal type:
10.5mm .413inch
- **High capacity**
CP Relay provides low profile spacesaving advantages while offering high continuous current of 25 A(1 hour).
- **Sealed construction suitable for harsh environments**
- **Simple footprint pattern enables ease of PC board layout**

- **“PC board terminal” and “Surface mount terminal” types available**
SMD automatic mounting is possible for surface mount terminal types because tube packaging is used.

TYPICAL APPLICATIONS

- Power windows
- Auto door lock
- Power sunroof
- Memory sheet
- Wiper
- Defogger
- Blower fan
- EPS
- ABS etc.

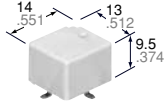
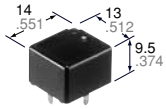

mm inch

RoHS Directive compatibility information
<http://www.nais-e.com/>

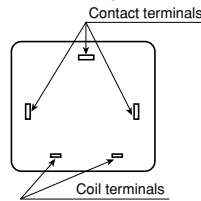

SPECIFICATIONS

Contact		1 Form A	1 Form C
Arrangement		1 Form A	1 Form C
Contact material		Ag alloy (Cadmium free)	
Initial contact resistance (Initial) (By voltage drop 6V DC 1A)		Typ. 3 mΩ (N.O.) Typ. 4 mΩ (N.C.)	
Rating	Nominal switching capacity	20 A 14 V DC	20 A 14 V DC (N.O.) 10 A 14 V DC (N.C.)
	Max. switching voltage	16 V DC	
	Max. carrying current	N.O. 40 A for 2 minutes 30 A for 1 hour (12 V at 20°C 68°F) 35 A for 2 minutes 25 A for 1 hour (12 V at 85°C 185°F)	
	Min. switching capacity ^{#1}	1 A 12 V DC	
Expected life (min. operations)	Mechanical (at 120cpm)		10 ⁷
	Electrical (at 6cpm)	Resistive load	Min. 10 ^{5*1}
			Min. 2×10 ^{5*2}
		Motor load	Min. 10 ^{5*3} Min. 2×10 ^{5*4}
Nominal operating power		640 mW	

#1 This value can change due to the switching frequency, environmental conditions, and desired reliability level, therefore it is recommended to check this with the actual load.

Characteristics		
Max. operating speed (at rated load)		6cpm
Initial insulation resistance ^{*5}		Min. 100MΩ (at 500 V DC)
Initial breakdown voltage ^{*6}	Between open contacts	500 Vrms for 1min.
	Between contact and coil	500 Vrms for 1min.
Operate time ^{*7}		Max. 10ms (at 20°C 68°F)
Release time (without diode) ^{*7} (at nominal voltage)		Max. 10ms (at 20°C 68°F)
Shock resistance	Functional ^{*8}	Min. 100 m/s ² {10 G}
	Destructive ^{*9}	Min. 1,000 m/s ² {100 G}
Vibration resistance	Functional ^{*10}	10 Hz to 100 Hz, Min.44.1 m/s ² {4.5 G}
	Destructive	10 Hz to 500 Hz, Min.44.1 m/s ² {4.5 G}
Conditions in case of operation, transport and storage ^{*11} (Not freezing and condensing at low temperature)	Ambient temp	-40°C to +85°C -40°F to +185°F
	Humidity	5% R.H. to 85% R.H.
Mass		Approx. 4g .14 oz

Remarks

- *1 At nominal switching capacity, operating frequency: 1s ON, 9s OFF
- *2 N.O.: at 5A (steady), 25A (inrush)/14V DC, operating frequency: 0.5s ON, 9.5s OFF
- *3 At 20A 14V DC (Motor lock), operating frequency: 0.5s ON, 9.5s OFF
- *4 N.C.: at 20A 14V DC (brake), operating frequency: 0.5s ON, 9.5s OFF
- *5 Measurement at same location as "Initial breakdown voltage" section
- *6 Detection current: 10mA
- *7 Excluding contact bounce time
- *8 Half-wave pulse of sine wave: 11ms; detection time: 10μs
- *9 Half-wave pulse of sine wave: 6ms
- *10 Detection time: 10μs
- *11 Refer to Conditions for operation, transport and storage mentioned in AMBIENT ENVIRONMENT
Please inquire if you will be using the relay in a high temperature atmosphere (110°C 230°F).

ORDERING INFORMATION

Ex. CP - -

Contact arrangement	Mounting classification	Coil voltage (DC)	Packing style
1a: 1 Form A 1: 1 Form C	Nil: PC board terminal SA: Surface-mount terminal	12 V	Nil: Tube packing X: Tape and reel packing (picked from the NC terminal side) Z: Tape and reel packing (picked from the coil terminal side)

Notes: 1. Tube packing: Carton (Tube): 40 pcs.; Case: 1,000 pcs. * PC board terminal type only.
2. Tape and reel packing: Carton (Tape and reel): 300 pcs.; Case: 900 pcs. * Surface-mount terminal type only.
3. Surface-mount terminal type is available only for 1 form C contact arrangement.

TYPES

1. PC board terminal type

Contact arrangement	Coil voltage	Part No.
1 Form A	12V DC	CP1a-12V
1 Form C	12V DC	CP1-12V

2. Surface mount terminal type

Contact arrangement	Coil voltage*1	Part No.
1 Form C	12V DC	CP1SA-12V-X
1 Form C	12V DC	CP1SA-12V-Z

Notes:

1. *1 24V DC type is also available by request. Please contact us for details.
2. Tape and reel packing symbol "z" or "x" are not marked on the relay.

COIL DATA (at 20°C 68°F)

Nominal voltage, V DC	Pick-up voltage, V DC (Initial)	Drop-out voltage, V DC (Initial)	Coil resistance Ω	Nominal operating current mA	Nominal operating power mW	Usable voltage range, V DC
12	Max. 7.2	Min. 1.0	225 \pm 10%	53.3 \pm 10%	640	10 to 16

* Other pick-up voltage types are also available. Please contact us for details.

DIMENSIONS

mm inch

1. PC board terminal type

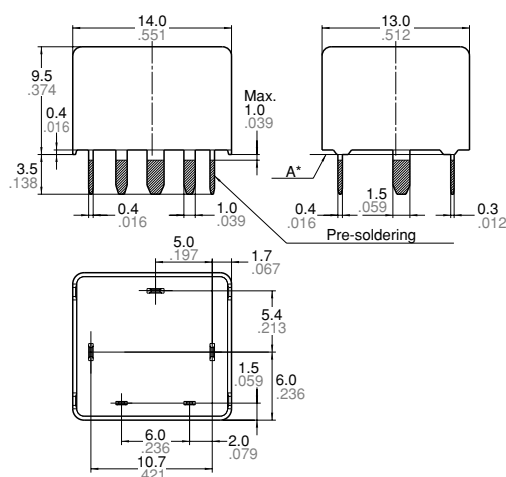

Schematic (Bottom view)
1a

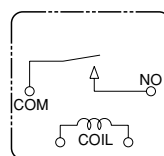

PC board pattern (Bottom view)
1a

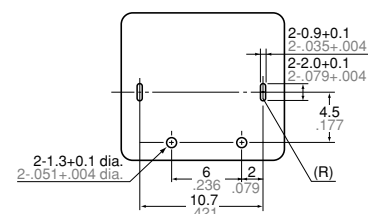

1c

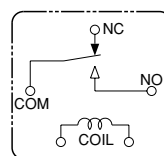

1c

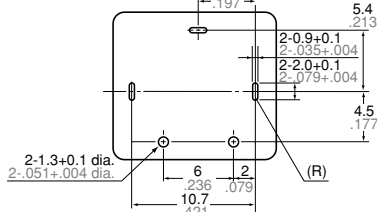

Dimension:

Max. 1mm .039 inch: $\pm 0.1 \pm 0.04$

1 to 3mm .039 to .118 inch: $\pm 0.2 \pm 0.08$

Min. 3mm .118 inch: $\pm 0.3 \pm 0.12$

General tolerance

$\pm 0.1 \pm 0.04$

$\pm 0.2 \pm 0.08$

$\pm 0.3 \pm 0.12$

* Dimensions (thickness and width) of terminal specified in this catalog is measured before pre-soldering.
Intervals between terminals is measured at A surface level.

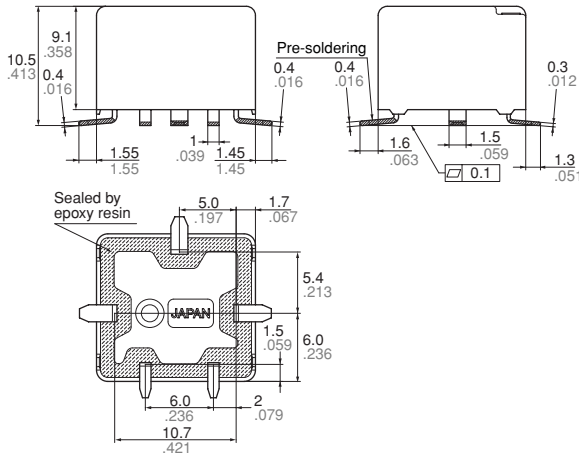

Schematic

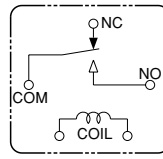

Recommendable mounting pad (Top view)

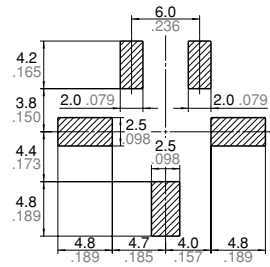

<u>Dimension:</u>	<u>General tolerance</u>
Max. 1mm .039 inch:	±0.1 ±.004
1 to 3mm .039 to .118 inch:	±0.2 ±.008
Min. 3mm .118 inch:	±0.3 ±.012

REFERENCE DATA

1. Coil temperature rise

Sample : CP1-12V, 6pcs
 Point measured : Inside the coil
 Contact carrying current, 5A, 10A, 15A, 20A
 Resistance method, ambient temperature 85°C 185°F

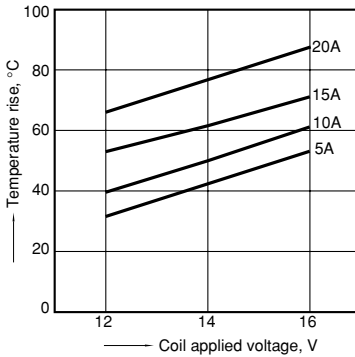

2. Max. switching capability (Resistive load)

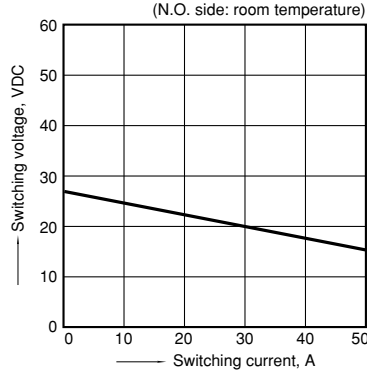

3. Ambient temperature and operating voltage range

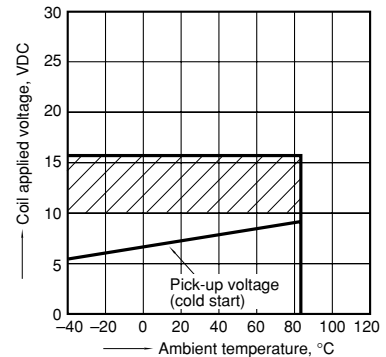

4. Distribution of pick-up and drop-out voltage

Sample : CP1-12V, 100pcs
 Ambient temperature : 20°C 68°F

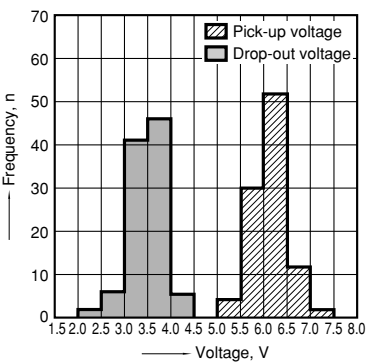

5. Distribution of operate time

Sample : CP1-12V, 100pcs
 Ambient temperature : 20°C 68°F

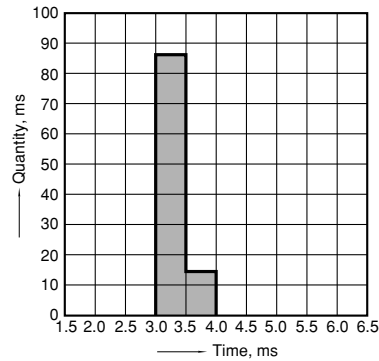

6. Distribution of release time

Sample : CP1-12V, 100pcs
 Ambient temperature : 20°C 68°F
 * With diode

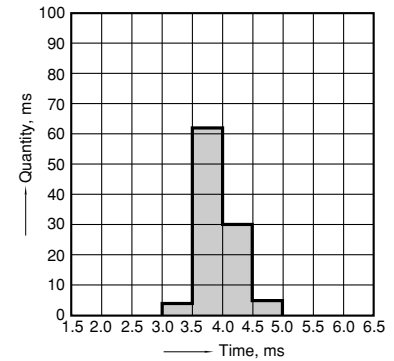

7-(1). Electrical life test (at rated load)

Sample : CP1-12V
 Quantity : n = 4 (NC = 2, NO = 2)
 Load : Resistive load (NC side : 10A 14 V DC,
 NO side : 20 A 14 V DC)
 Operating frequency : ON 1s, OFF 9s

Ambient temperature : Room temperature

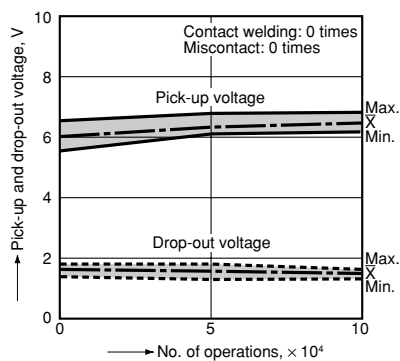

7-(2). Electrical life test (Motor free)

Sample : CP1-12V, 3pcs.
 Load : 5A, Inrush 25A, Brake current 15A,
 Power window motor load (Free condition).
 Operating frequency : (ON : OFF = 0.5s : 9.5s)
 Ambient temperature : Room temperature

Circuit :

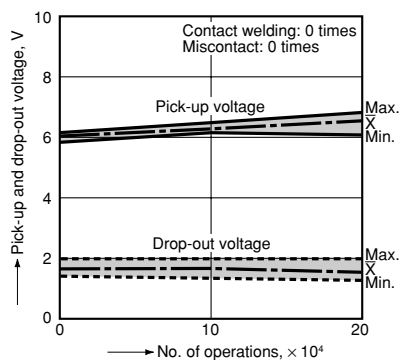
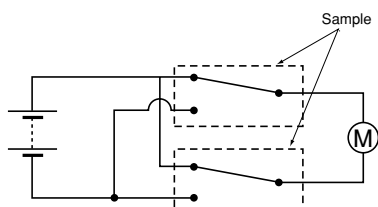

For Cautions for Use, see Relay Technical Information.