

Electronic Metal Halide Ballast for 70 Watt Lamps

DRIVING the Future of Luminaires!

5EU "Resonance Start" Technology

- Superior **HOT** Re-Strike performance with programmed lamp cooling off periods
- Increased remote mounting distance from ballast to lamp
- Enhanced start ability for broadened quartz lamp compatibility



Shown with side leads (bottom leads also available)

Features & Benefits:

- One ballast for all voltages from 120V through 277V
- Excellent line regulation; $\pm 0.5\%$ output variation with $\pm 10\%$ change in line voltage.
- Reduction in visual flicker & increased lamp life.
- Increased reliability and safety with lamp "Turn-off Function": (Resets by cycling line voltage "off-then-on")
- Ease of assembly; only one unit to mount.
- Light weight (1.3 lbs.)
- Energy Savings: Up to 17% vs. magnetic and up to 80% vs. halogen.
- Eliminates long term lamp cycling. No need to wait for lamps to cycle to identify replacement.
- Sound Rated "A" for indoor applications.
- Thermally protected/ Transient protected.

Lamp Maintenance Notice:

- To start new lamps or replaced lamps, turn off the ballast input voltage for 10 seconds then back on.
- If lamp or wiring is defective the ballast will "shut down" in 1.5 to 30 minutes depending on the fault condition.



Specifications:

Lamps ¹	70W Metal Halide M139, M143, M98 Ceramic or Approved Quartz Lamp
Input Voltage	Universal 120-277V 50/60 hertz
Power Factor	High
Input Power	78W
Input Current (Maximum)	120V: 0.67A / 277V: 0.29A
Harmonic Distortion	<15%
Lamp Frequency	170 Hertz Square-Wave
EMI/ RFI	Complies with FCC 18C, non consumer limits
Lamp Current Crest Factor	1.2 Typical
Safety	UL Outdoor Type 1, Suitable for Recessed Use
Thermal Protection	Functions at approximately 100°C hot spot
Warranty ²	5 years-max. case temperature <75°C; 3 years-max. case temperature <80°C
Minimum Ballast Temp.	-15° C/ +5° F
Maximum Mounting Distance	See Remote Wiring Section on Page 2

Note 1: Consult lamp manufacturers for lamp compatibility approval.

Note 2: Warranty is based on maximum operating time of 4000 hours per year. For additional operating hours consult with Aromat Application Engineering.

Product Summary

LAMP	70W Metal Halide M139, M143, M98 Ceramic or Approved Quartz Lamp		
Input Volts	120V-277V 50/60Hz		
Model Number	M7012-27CK-5EU	M7012-27CK-5EU-F	M7012-27CK-5EU-J
Mounting/ Lead Exit	No Feet with Side Leads Exit	Feet with Side Leads Exit	Studs with Bottom Lead Exits
Safety	Recognized Component: 	Listed: 	Listed: 
Lamp Holder	Minimum 4KV Pulse Rated		

Aromat reserves the right to change any of the above performance characteristics without notice.

For More information, call: 1-888-4-AROMAT
Visit our Web Site: www.aromat.com

Aromat Corporation
(Matsushita Electric Works, America)

Wiring Diagram:

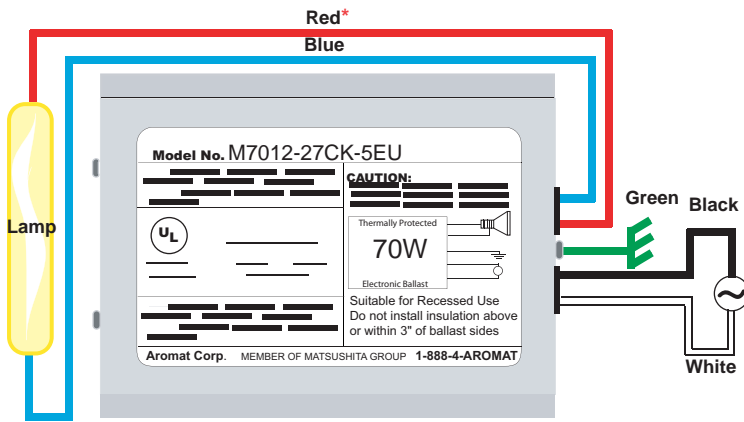

Safety Instructions:

- Always disconnect power to the entire fixture before installation and/or removal of ballasts or controls.
- Ballast case must be grounded.
- Install per national and local electrical codes.
- Dispose of any replaced ballasts and lamps properly.
- **DO NOT** connect lamp leads to ground or neutral.

Dimensions: - Millimeters / Inches

M7012-27CK-5EU-F

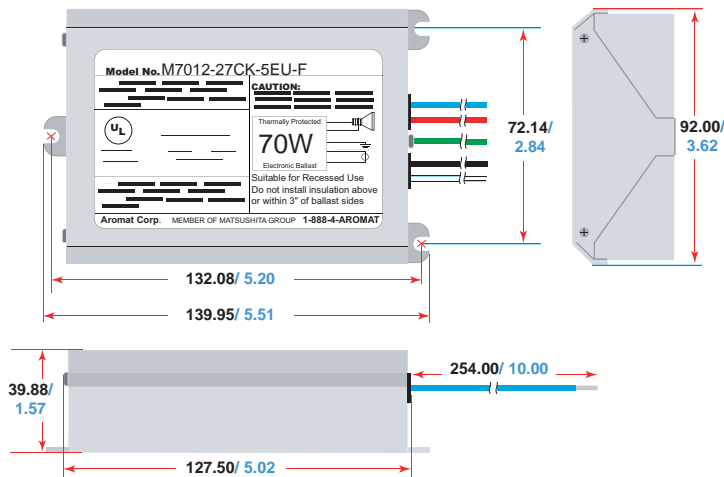

M7012-27CK-5EU-J

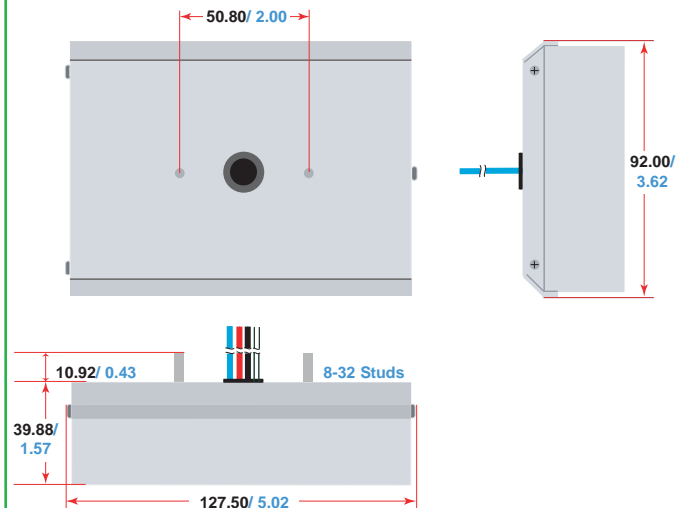

M7012-27CK-5EU

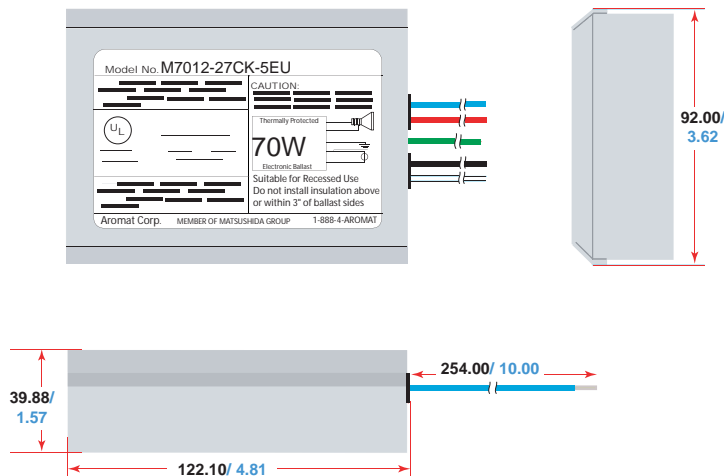

NOTES

- For additional installation and operational information, please refer to: *Aromat Application Guidelines*.
- Dimensional Tolerances:**
 - Case: $\pm 1.0\text{mm} / \pm 0.039"$
 - Lead Wires: $+50\text{mm} / +2"$
 $-30\text{mm} / -1"$
 - Lead Length: Nominal 10": "EU & F" Models
Nominal 7": "J" Model
 - Slot width on "F" mounting tabs: $5.0\text{mm} / 0.20"$
- Remote Wiring Guidelines:**
 - Each lamp's lead wires must be run in a separate conduit from the input power leads to achieve good EMI performance and maximum remote capabilities.
 - Individual lamp lead wires must be used for external fixture extensions using wire types SF-2 (Equivalent to SEW-2 or 3071) or SFF-2 (Equivalent to SEWF-2 or 3070) or alternately, if approved by Aromat, high voltage fixture wire with a 18 AWG conductor and a 1000VAC minimum voltage rating. Temperature rating is especially critical if the lamp lead extension wires are directly connected to lamp-holder terminals.
 - Maximum Remote Distances:
15 feet in a minimum 1/2" internal diameter conduit, pipe or flexible conduit
For longer remote mounting distances, consult with Aromat.
 - Using Service Power cords (types SJ, SV, SO, etc.) or metal clad cable assemblies for lamp lead extension wire are not recommended as they are **NOT** compatible with the above characteristics, can cause starting problems and shall not be used unless Aromat gives written approval.