



Dust removal at sealing material

OUTLINE / PREVIOUS

Customer: Rubber commodity manufacturer

Process: Inspection process

After a rubber sealing material is molded, dust is removed from a surface of a rubber before inspected by an image inspection apparatus.

PROBLEM

Product failure due to attachment of dust should be prevented.

SOLUTION

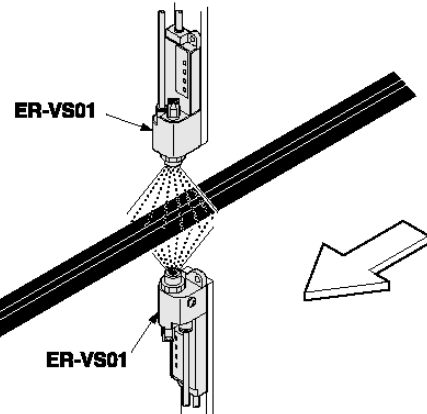

MODEL / HOW TO

ER-VS01

A shower nozzle is used to blow air strongly to remove dust.

BENEFIT 1 Safe design

ER-VS01 incorporates “checking function” for notifying the replacement or cleaning time of the discharge needle and “abnormal discharge monitoring function” for preventing troubles due to an abnormal discharge.

BENEFIT 2 Easy maintenance of the discharge needle

The discharge needle can be removed from the rear of the main unit, so there is no need to remove the nozzle when replacing the needle. Maintenance is easy even when the ion air outlet is located close to the object.

BENEFIT 3

