



Confirmation of the type of plates

OUTLINE / PREVIOUS

Customer : Automobile components manufacturer

Machinery: Plate press fitting machine

Before a plate is pressed into a part of evaporator to adjust air flow, the type of plate is judged. As each dimension is same, the difference of inside rim dimension is detected by the amount of light blocked off.

PROBLEM

Considering the structure of the unit, the sensor to set even in a small space is needed, because the detection with fibers was unstable.

SOLUTION

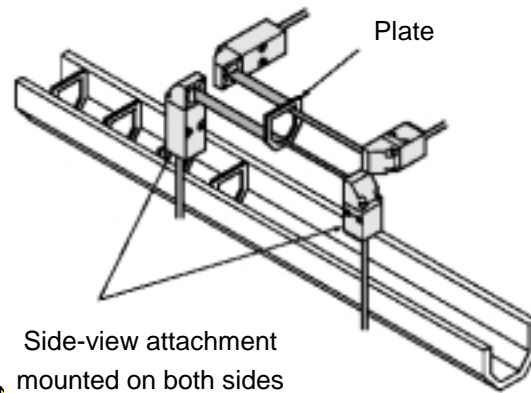

Side-view attachment mounted on both sides

MODEL / HOW TO

HL-T1005A **HL-AC1**
HL-T1SV1

When you mount side-view attachment **HL-T1SV1** on the sensor head, you can set even in a small space.

BENEFIT 1

Save space

HL-T1005A is the industry's smallest. (emitter : 34×15×15mm, receiver : 19×15×15mm)
 In addition, you can set as you like if you mount optional **HL-T1SV1** on the sensor head to vent light beam by 90 degree angle.

BENEFIT 2

High-precision

A high resolution of 4μm (at an average 64 cycles) allows high precision size judgment.

BENEFIT 3

Easy operation

HL-AC1 is equipped with a large dual digital display. All settings can be easily performed by using four-way allow key and checking digital display.