

Panasonic

ideas for life

FAY_b Laser Marker

LP-*V* SERIES
LP-*W* SERIES

FDA
Conforming to
FDA regulations
(Some models only)

CE
Conforming to Low Voltage
and EMC Directive
(Some models only)



Innovative fiber laser (FAY_b) markers dramatically improve productivity and offer broad advantages over conventional laser marking technologies.

LP-V, LP-W SERIES



Extensive line of advanced FAY_b lasers
Evolving toward next-generation applications

Metals



Resin coloring



Semiconductors



High-performance galvanoscanner

Improved productivity

Response speeds of at least twice of previous models mean dramatically reduced tact time and support for high-speed production lines.

12 W short-pulse laser*

Beautiful super-small marking

Exceptional-quality lasers with high energy density deliver sharp, beautiful marking.

* LP-V series

Innovative FAY_b laser

Space- and energy-efficient

Thanks to their uniquely simple design, FAY_b lasers deliver completely air-cooled performance in a space-saving package, allowing smaller head and controller footprints.

Choose the model that is right for your application

Convenient operation

In keeping with Panasonic Electric Works SUNX's unyielding commitment to unrivaled ease of use and operability, the LP-V and LP-W series can be controlled from a computer with the Laser Marker NAVI application or by using a simple touch panel console.

FAY_b (Fiber Amplified Ytterbium), a proprietary technology of using optical fiber to excite and amplify a laser beam, is setting a new standard for laser markers.

FAY_b laser markers have built on energy efficiency, high reliability, and other FAY_b advantages from the LP-F series, evolving further to offer significantly improved marking quality and speed.

Panasonic Electric Works SUNX invites you to experience the unrivaled advantages of the LP-V and LP-W series.

High-speed marking at 700 cps*

Three times the productivity means less time and equipment.

Capable of marking at speeds of up to 700 cps, the LP-V series can deliver more than three times the productivity of previous models thanks to its shorter tact time. Enjoy dramatically reduced equipment costs since a single laser marker can now handle applications that previously required multiple units.

Three times the speed

Previous models

200 cps

→

LP-V SERIES

700 cps

*LP-V series

Reduced marking tact time

The LP-V and LP-W series feature a high-performance galvanoscanner whose acceleration, deceleration, and response speeds exceed those of previous models by at least 200 %, delivering dramatically shorter marking tact times.

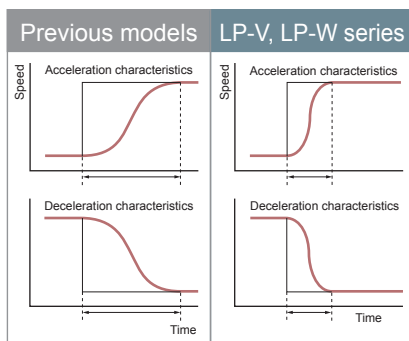

Simulated Characteristics of High-performance Galvanoscanner

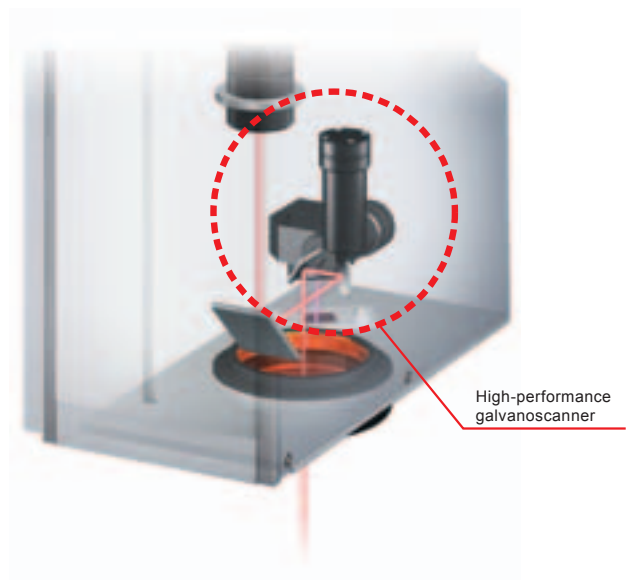

LP-V, LP-W SERIES

Accurate marking at high speed

Panasonic Electric Works SUNX's proprietary galvanoscanner control technology keeps marking accurate and aligned, even at high speed.

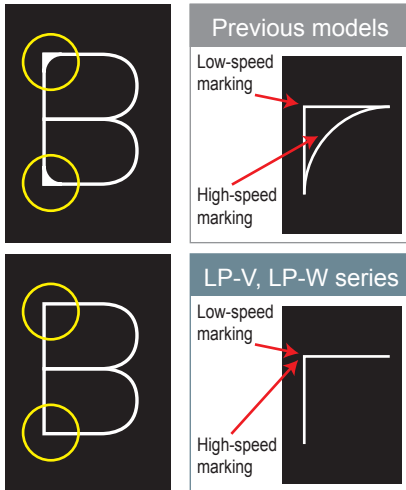

Marking order optimization feature

The LP-V and LP-W series automatically determine the most efficient marking order, further reducing tact time.

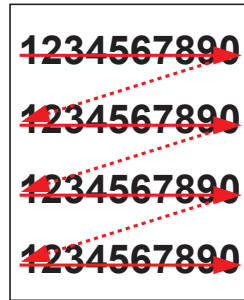

Not optimized

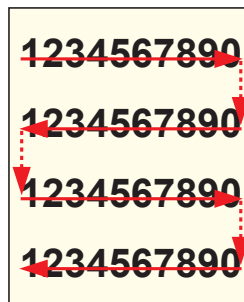

Optimized

Rank and Offset features

Rank and Offset features let you change marking data as well as the marking position without changing file numbers. Depending on how it is employed, this capability can provide dramatic improvements in work efficiency, for example by replacing part of a character string quickly for each target object.

Rank feature

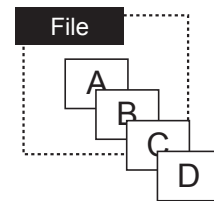

The rank feature is ideal for applications requiring that **part of the character** string be replaced quickly for each target object.

Offset feature

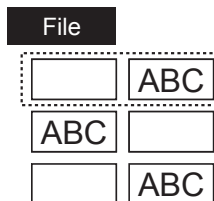

The offset feature is ideal for applications requiring that **the marking location** be changed quickly for each target object.

Improved marking resolution

Panasonic Electric Works SUNX's proprietary servo technology delivers marking resolutions of 1 μm 0.039 mil*, enabling more accurate marking - a key capability when generating super-small characters.

*LP-W052

Serial data marking feature

With previous models, data such as characters and 2D codes had to be sent from the control computer separately. Thanks to revamped software, the LP-V and LP-W series support batch transfers of data to the laser marker, simplifying complex code transfer procedures and preventing marking mistakes caused by data mix-ups.

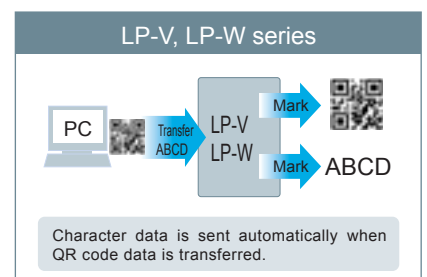
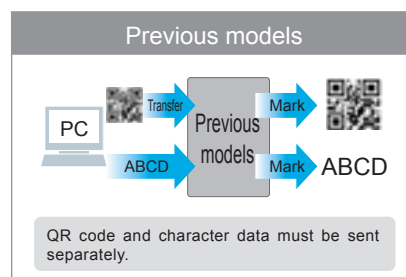

Step and Repeat feature

Step and Repeat provides high-speed batch marking for printed circuit boards and plastic packaging such as trays and lead frames. Used in combination with the counter feature, Step and Repeat can also be used to generate serial numbers. This capability helps increase speeds on semiconductor and electronic component production lines where short tact times of 0.1 seconds are imperative.

● Step and Repeat example

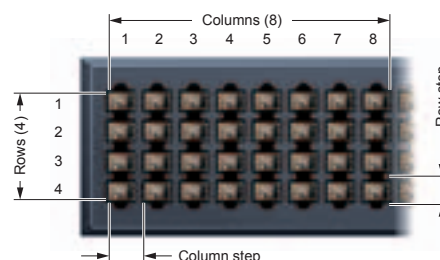

● Example counter settings

ABC No.1	ABC No.2	ABC No.3
ABC No.4	ABC No.5	ABC No.6
ABC No.7	ABC No.8	ABC No.9

The counter start position and direction can both be set.

The uncompromising pursuit of high-quality marking that is fast, beautiful, and finely detailed.

A complement of technologies drives high marking quality.

The LP-V and LP-W series take advantage of a number of new technologies to deliver even higher definition marking. Every aspect of the product development process—from the superior beam produced by the FAYb system to control technologies designed to create more beautiful output—reflects a single-minded dedication to improving marking quality.



The LP-V series is ideal for marking metals and coloring resins.

The FAYb laser used in the LP-V series features a pulse that is significantly shorter than the pulse width used in conventional models. This configuration offers reduced thermal effects and is ideal for use in marking applications.

Impressive capabilities for marking metals

The FAYb laser used in the LP-V series features a high peak power of 20 kW, enabling it to generate sharp, deep marking and crisp, black output on metals that require high levels of power.

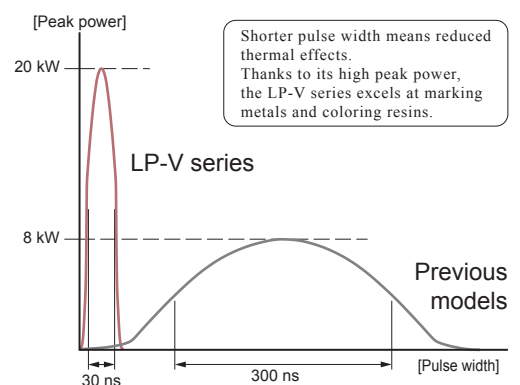

Beautiful resin coloring

The LP-V series has it all, delivering high peak power in a short-pulse laser with low thermal effects to enable beautiful, print-like color marking on resins.



Advantages for large target objects and multi-unit layouts

Available 160 mm × 160 mm **6.3 in × 6.3 in** wide-area models let the LP-V series accommodate wide marking areas.

- Support for batch marking of multi-unit layouts
- No set changes
- Fewer units required
- Support for marking of large target objects

LP-V, LP-W_{SERIES}

The LP-W052 generates super-small marking that is vivid and uniform, making it ideal for low-profile packages.

It is critical that marking on low-profile electronic components such as chip-size packages has little effect on the target object. Laser output control and a high-speed galvanoscanner make it possible to keep the marking depth to just 10µm **0.39 mil** or less.

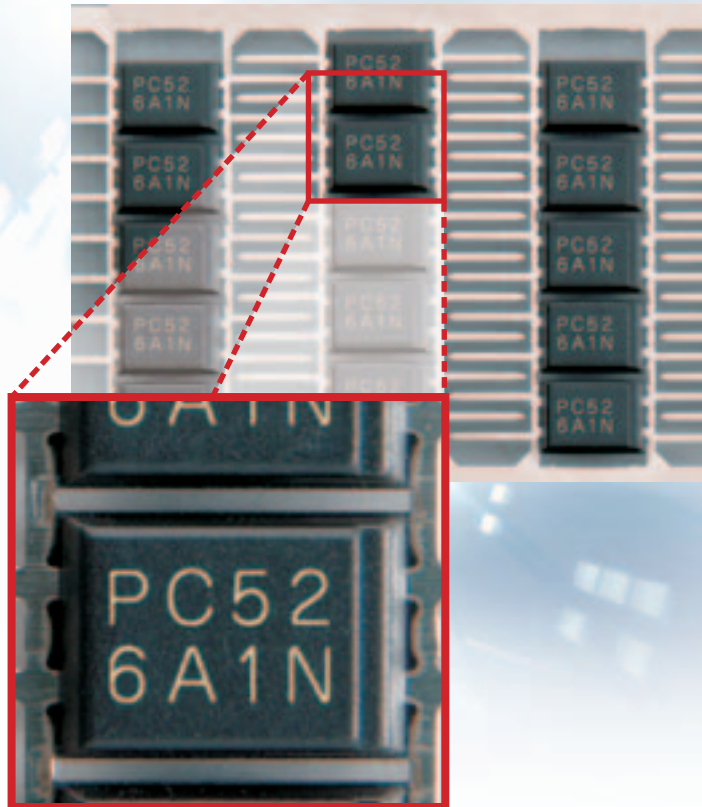



Technologies behind high-quality marking

The LP-V and LP-W series take advantage of a number of new technologies to deliver high-definition marking.

Intersection correction

Advanced control functionality prevents excessively deep marking where lines in characters intersect, eliminating the tendency of overlapping lines to distort the shape of output characters in previous models.

Previous models	LP-V, LP-W series
	
Lines overlap, distorting character shape.	Uniform marking Optimized adjustment prevents excessively deep marking caused by overlapping lines, avoiding distortion of character shapes.

Depth control

The LP-V and LP-W series automatically adjust marking strength at locations susceptible to deep marking such as the beginning and ends of lines and areas where straight and curved lines intersect. The result is beautiful output with uniform line depth.

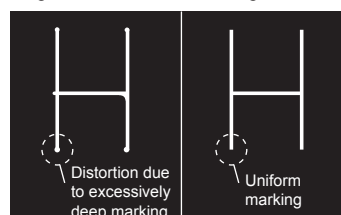

Coloring adjustment

The LP-V and LP-W series control coloring by adjusting the laser power, scanning speed, and marking pulse cycle for each set line, giving products a broad range of expression.



Advantages of the innovative FAY_b fiber system

The FAY_b system resolves the problems of conventional laser markers.

The FAY_b system provides long life and high efficiency in a compact package that is completely air-cooled. Equipment footprint, constraints on installation orientation, lamp replacement, adjustment of mirrors and other optical components, running costs, and other issues associated with conventional laser markers have all been addressed.

* LD: Laser diode

Innovative fiber system (FAY_b)

Doping with the rare-earth element ytterbium, which has a beneficial effect on beam width, inside optical fiber allows the laser beam to be excited and amplified in an extremely efficient manner, yielding stable output. In addition, the use of a design where the excitation laser diodes are only activated during marking results in dramatically extended laser diode life.

• FAY_b system principles and design

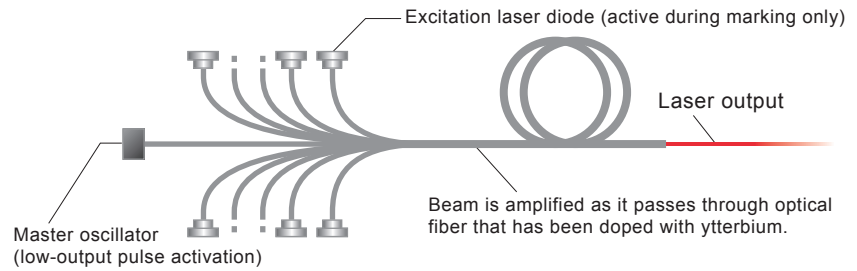

• Conventional principles and design

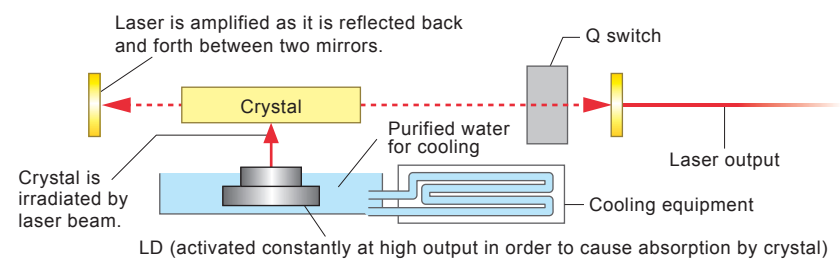

Continuing evolution of the FAY_b system

The LP-V and LP-W series build on the strengths of previous models (the LP-F series) by delivering improved performance.

■ Advantages of short-pulse lasers in coloring applications

The LP-V series features a newly developed short-pulse laser for reduced thermal effects and more vivid color.



■ Energy efficiency

Despite 20 % higher laser output than previous models, the LP-V series delivers a 10 % reduction in power consumption.

■ Improved startup and shutdown

Laser output now reaches the set level instantaneously, helping to keep marking crisp and sharp at the beginning and end of characters.

■ Improved laser output efficiency

The laser beam is amplified in the unit's head. This design eliminates the power attenuation ordinarily experienced as the light travels over the transmission fiber, enabling more efficient laser output (LP-V series).

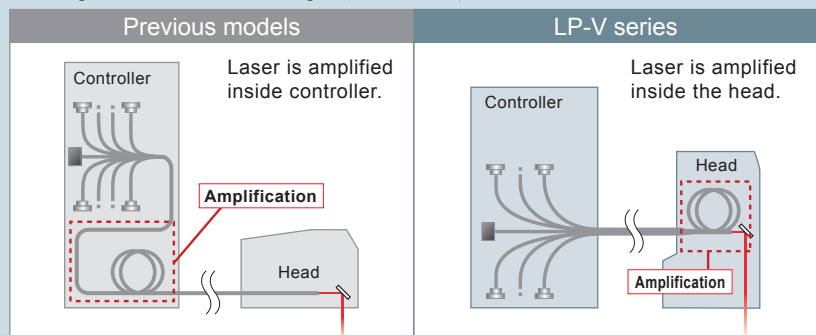

● Simulated laser startup characteristics

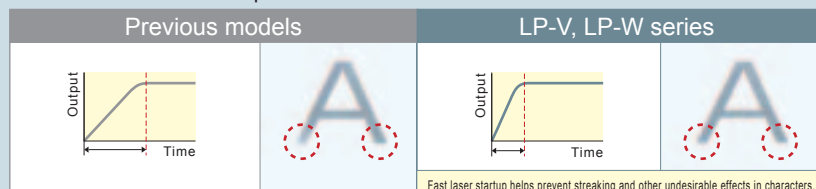

LP-V, LP-W SERIES

High efficiency with less energy

Because it amplifies the laser inside ytterbium-doped fiber, the FAY_b system delivers 50% conversion efficiency, more than twice the level that is possible with conventional laser markers. An energy-efficient design keeps power consumption to approximately 1/3 the level of conventional laser markers.

● Comparison of conversion efficiency

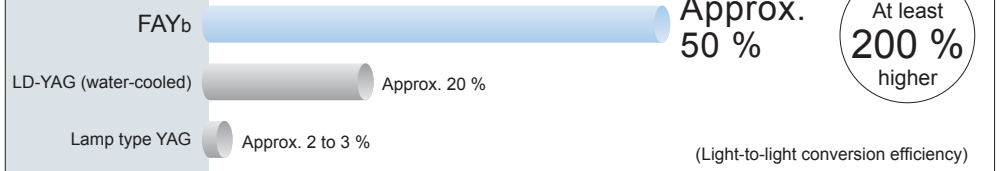

● Comparison of power consumption

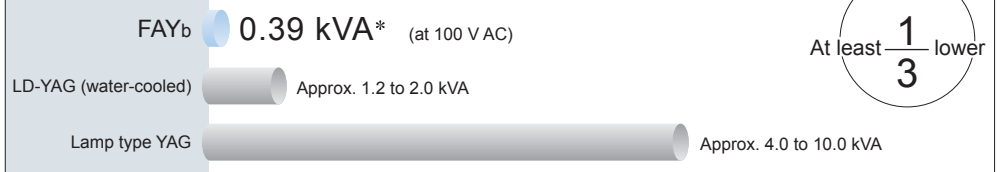

* LP-V series

Completely air-cooled

By utilizing a heat-suppressing design with exceptional dissipation characteristics, Our company was able to develop a completely air-cooled oscillator.

No consumables

No additional facilities

No liquid coolant

Long life

The FAY_b system uses a well conceived design that pairs a low-output master oscillator with a laser diode that is only activated during marking, reducing the load on the diode and dramatically improving the conversion cycle compared to conventional designs that use high-output diodes that are always active. Our company uses laser diodes with the same high levels of reliability and durability as units used for optical communication applications.

Dust-proof design

To compensate for its extreme susceptibility to even small pieces of dirt and dust, the galvanoscanner is protected by an effective dust-proof design. This feature guarantees marking consistency over the long term.

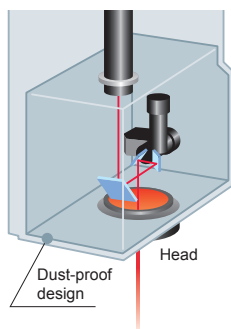

Space-saving design

The system's head has a footprint smaller than a B5 sheet of paper, and the ability to be installed in any orientation ensures that no space will be wasted. Both LP-V and LP-W series systems are surprisingly compact since they do not require coolant pipes or additional cooling equipment. The result is reduced equipment and deployment costs.

Compared to LD-YAG laser markers (water-cooled system)

Approx. $\frac{1}{3}$ the installation space by volume

Controller

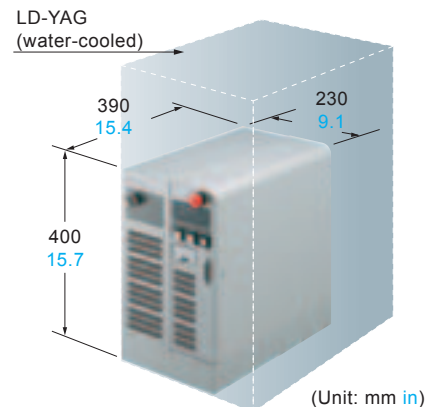

Compared to LD-YAG laser markers (water-cooled system)

Approx. $\frac{2}{3}$ the space by volume

Approx. $\frac{1}{2}$ the installation footprint by area

Head

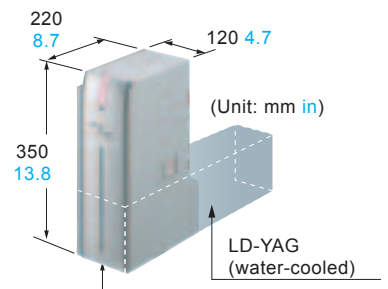

* When installing an air-cooled system, be sure to leave sufficient ventilation space for cooling.

No-alignment installation in any orientation

Because their oscillation method does not require the use of optical mirrors, FAY_b laser markers are not susceptible to optical axis misalignment caused by vibrations or other mechanical disturbances. When moved, the system does not need to be realigned by a specialist engineer. In addition, its completely air-cooled, space-saving design can be installed in any orientation as dictated by available space, target object characteristics, transport line type, and other factors.

* When installing laser markers facing one another, take care to prevent the light from each laser from entering the irradiation port of the unit facing it.

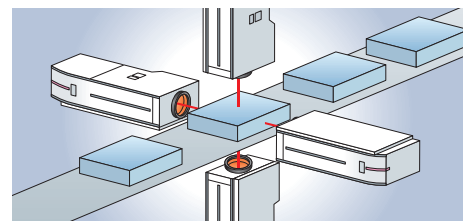

Convenience means selecting the mode of operation that is right for your application.

Control multiple laser markers with the new Laser Marker NAVI application. The LP-V and LP-W series come standard with application software for easily configuring marking data.



Batch laser marker management

Now you can connect multiple laser markers to a single computer for centralized management of all connected markers and associated configuration data. Easy, straightforward monitoring of settings and operational status rounds out the application's management capabilities, ensuring that advanced technology will pave the way for dramatically improved work efficiency.

* A USB hub is required separately.

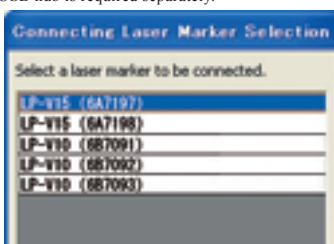

Intuitive interface

Laser Marker NAVI's simple, intuitive mouse-driven interface makes it easy to configure marking conditions and positions in setting files, allowing you to easily create marking layouts according to plan. The application also allows your computer to monitor system operation, and you can check error logs and the I/O monitor at the same time.

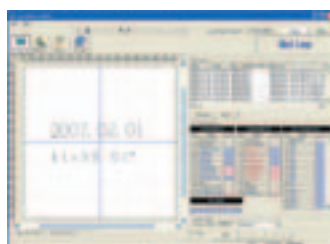

System operation monitor screen

Offline configuration

Now you can create and save data at a remote location such as an office and later transfer it to the laser marker on-site for marking. Alternatively, you can avoid the need for an on-site computer entirely by using a USB memory stick and console to save data to the laser marker for marking*.

* You can also operate the laser marker using a monitor and mouse.

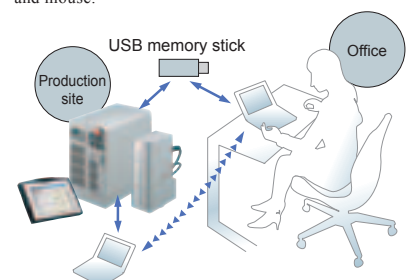

LP-V, LP-W_{SERIES}

The touch panel console is ready for immediate use at production sites.

LCD touch panel console (optional) provides unmatched ease of use.

Laser Marker NAVI included softwares

Logo data conversion software

Output logos and other graphical marks from DXF, BMP, or JPEG data and read marks using a scanner with Laser Marker NAVI.

* DXF is a data format developed by Autodesk, Inc. to facilitate the exchange of data between CAD applications.



Logo data editing software

Create and edit logo files without using commercial CAD software.

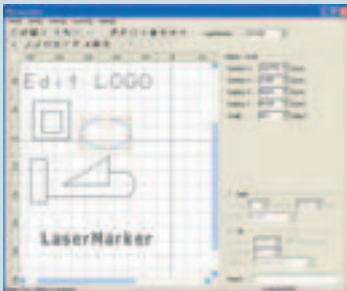

Font maker software

Create original fonts.

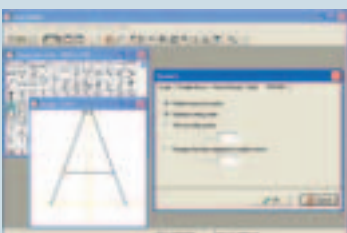

* Simulated screen image.

Intuitive operation

The console uses an intuitive, easy-to-understand hierarchical interface. The ability to generate a test mark or check data being output from all screens facilitates quick operational response. Combine features such as changing the display magnification, displaying target object images, and configuring device offsets for even greater convenience.

Quick review

A color touch panel designed for maximum ease of use and viewing provides stress-free operation by displaying marking data and settings immediately. An ergonomic design makes it equally easy to use in both handheld and equipment-mounted configurations.

Control with off-the-shelf monitor and mouse

* Customers are encouraged to verify proper operation of system components in advance when using off-the-shelf hardware.



LP-V and LP-W series laser markers can also be used with a standard computer monitor and mouse.

Convenient features meet a variety of needs.

USB connectors

The ability to store system settings on standard USB memory sticks lets you backup marking settings or copy the same set of settings to multiple laser markers, delivering improved ease of use compared to the floppy disk drive used by previous models. (The system also supports USB-connected floppy disk drives.)

* Customers are encouraged to verify proper operation of system components in advance when using off-the-shelf hardware.



Dual pointers

LP-V and LP-W series laser markers incorporate dual pointers created by a red guide light to make it easier to check and adjust the marking position and focus distance. This feature also enables you to easily fine-tune the focus distance.

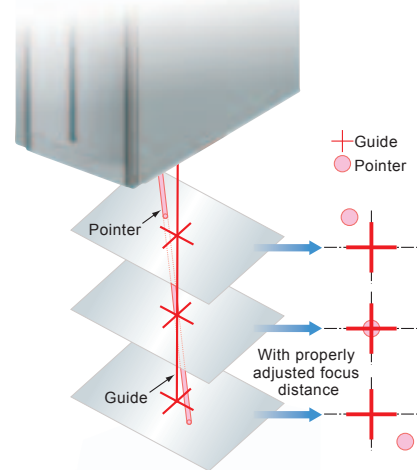

Easy marking of Adobe® Illustrator® data

Data created by Adobe® Illustrator® can be converted into marking data by "ExportVec", which is a standard-included software. Logos or marks can be easily marked while staying true to the original Adobe® Illustrator® graphic images.



Graphic drawn by Adobe®Illustrator®

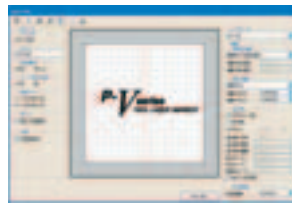
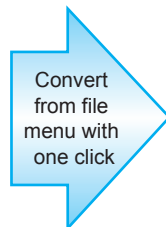

Hatching editing of marking data (VEC format) is also possible

* Adobe® Illustrator® is a registered trademark of Adobe Systems Incorporated in the United States and other countries.

Guide laser feature for checking marking position

LP-V and LP-W series laser markers use an easily visible red guide laser to trace out the set marking data and the marking position, allowing you to visually check the marking position before actual marking begins.

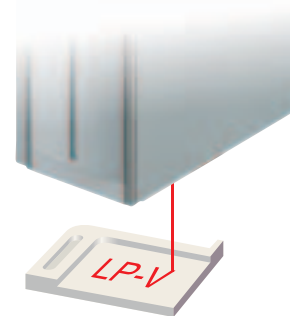

Terminal block monitor and error log display features

An I/O confirmation monitor provides on-screen confirmation of terminal block status, allowing you to easily simulate equipment tests. An error log display feature saves information about system errors for later viewing.



● I/O confirmation monitor feature

Power check feature

This convenient feature allows one-touch confirmation of the current attenuation factor relative to the laser's output when the unit shipped. Total laser irradiation time is also displayed on the screen to simplify system maintenance and management.

Password feature

A password feature dramatically improves safety and security by restricting users' ability to input certain information and protecting system settings, enabling safe and convenient use of the system for design, technical support, facilities, and production workers.

Focus adjustment feature

A newly developed focus adjustment feature simplifies system configuration at the time of installation by allowing the unit's focus to be adjusted without moving the head or fixture when changing the height of the target object or when system output becomes blurry or unfocused.

Help feature

LP-V and LP-W series laser markers include a help feature so that even first-time users are able to operate the system smoothly. Detailed messages inform users of potential configuration mistakes, reflecting our company's belief that a responsive and intuitive interface is an important aspect of system performance.

● Marking Samples

Character size (typical)		2D code	Logos
Arced and angled marking	Japanese kanji characters		Barcode

● Marking and Processing Examples

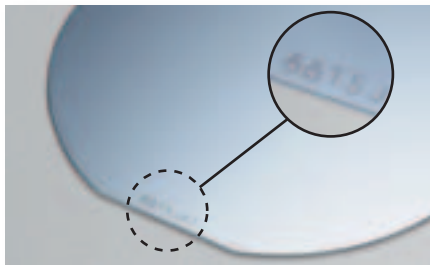

● Semiconductor wafers



● ICs (DIP)



● Automotive parts



● Molded resin parts



● Laser diodes



● Relay cases (resin coloring)



● Bearings



● Keypad tops (for mobile phones)

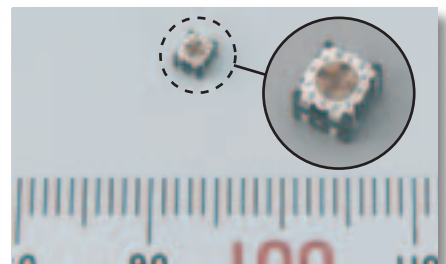

● Trimmer potentiometers (super-small marking)



● Product nameplates



● Drill bits



● Automotive illuminated buttons

Specifications

Type	General-purpose type	Wide-area type	For semiconductor packages (small-spot type)
Item Set model No.	LP-V10U	LP-V15U	LP-W052U
Distance from target object (Note 1)	190 mm 7.5 in	350 mm 13.8 in	127 mm 5.0 in
Marking laser	Class 4 Yb fiber laser; wavelength: 1.06 μm 0.042 mil		
Average output (Note 2)	12 W (pulse oscillation)		5 W (CW oscillation)
Guide laser / pointer	Class 2 semiconductor laser; wavelength: 655 nm 0.026 mil		
Marking range	90 × 90 mm 3.5 × 3.5 in	160 × 160 mm 6.3 × 6.3 in	55 × 55 mm 2.2 × 2.2 in
Scanning speed	Max. 12,000 mm/s		Max. 6,000 mm/s
Line speed (Note 3)	240 m/min or less		120 m/min or less
Installation orientation	All		
Character settings (character height, width)	0.2 to 90 mm 0.008 to 3.5 in (variable in 0.001 mm 0.00004 in steps)	0.2 to 160 mm 0.008 to 6.3 in (variable in 0.001 mm 0.00004 in steps)	0.2 to 55 mm 0.008 to 2.2 in (variable in 0.001 mm 0.00004 in steps)
Marking spacing (character spacing, line pitch)	0 to 90 mm 0 to 3.5 in (variable in 0.001 mm 0.00004 in steps)	0 to 160 mm 0 to 6.3 in (variable in 0.001 mm 0.00004 in steps)	0 to 55 mm 0 to 2.2 in (variable in 0.001 mm 0.00004 in steps)
Character arrays	Arched output: -180° to +180° (variable in 0.01° steps)		
Character types	Linear, proportional, monospaced, arched		
Barcodes	English uppercase letters, English lowercase letters, numerals, katakana, hiragana, kanji (JIS No. 1 and No. 2 standards), symbols, user-registered characters (up to 50)		
2D codes	Code 39, Code 128, ITF, NW-7, JAN/UPC, RSS-14 (GS1 DataBar), RSS (GS1 DataBar) Limited, RSS (GS1 DataBar) Expanded		
Composite codes	QR Code, Micro QR Code, Data Matrix, GST Data Matrix		
Logos / Graphics	RSS-14 (GS1 DataBar) CC-A, RSS-14 (GS1 DataBar) Stacked CC-A, RSS (GS1 DataBar) Limited CC-A, etc.		
Cooling method	BMP, DXF, HPGL, JPEG, AI (Note 4), EPS (Note 4)		
Power voltage	Forced air cooling		
Power consumption	100 to 120 V AC ±10 %, or 200 to 240 V AC ±10 % (automatic switching), 50/60 Hz		
Inputs	390 VA or less (100 V AC); 420 V or less (200 V AC)		
Outputs	310 VA or less (100 V AC); 360 VA or less (200 V AC)		
Marking object state	Remote, trigger, encoder (A), encoder (B), shutter control, laser excitation, alarm reset, emergency stop, laser stop, etc.		
Functions	Power supply (+12 V), remote, marking ready, marking, marking complete, laser excitation, warning, alarm, configuration complete, counter complete		
Emergency stop switch	Static, On the fly		
Ambient temperature	<ul style="list-style-type: none"> ● Marking order optimization ● Lot marking ● System offset ● Overlapping marking ● Proportional marking ● Rank marking ● I/O simulation ● Power and speed configuration by row or logo file 		
Ambient humidity	<ul style="list-style-type: none"> ● Intersection correction ● Logo data marking ● Shared character settings ● Backup ● Marking image display ● Offsetting marking ● Error log display 		
Weight	<ul style="list-style-type: none"> ● Counter marking ● Font creation and editing ● Guide laser ● Marking on long moving objects ● Marking time measurement ● Time hold ● Serial data marking 		
Laser Marker Driver & Utility OS (Note 5)	<ul style="list-style-type: none"> ● Current date marking ● Monospaced alignment ● Dual pointers ● Font selection ● Target object image display ● Step and repeat ● Power check and correction 		
	<ul style="list-style-type: none"> ● Deadline date marking ● Updating of operating screen display ● Focus adjustment ● Bold marking ● Operator adjustment ● I/O confirmation monitor 		
	Located on controller		
	0 to +40 °C +32 to +104 °F (Storage: -10 to +60 °C +14 to 140 °F) (No dew condensation or icing allowed)		
	35 % to 85 % RH (No dew condensation or icing allowed)		
Head	9 kg	10 kg	9 kg
Controller	22 kg	22 kg	22 kg
	Microsoft Windows® 7 Professional (32 bit) / Vista Business (32 bit) / XP Home Edition / XP Professional / 2000 Professional (Confirmed on English OS and Japanese OS)		

Notes: 1) It is output of a laser oscillator.

2) Distance from target object varies by approx. ±2 mm **±0.079 in** from model to model.

3) Varies by target object.

4) The PC installed Adobe® Illustrator® is necessary.

5) Windows® 7 Professional, Vista Business, XP Home Edition, XP Professional, and 2000 Professional are trademarks or registered trademarks of Microsoft Corporation in the United State and other countries.

Available FDA and CE marking compliant variations.

Model No. List

Type	Japanese model	FDA regulations conforming type	CE marking conforming type
General-purpose type	LP-V10U	LP-V10U-A	LP-V10U-C
Wide-area type	LP-V15U	LP-V15U-A	LP-V15U-C
For semiconductor packages	LP-W052U	LP-W052U-A	—

● Precautions for Proper Use



Laser safety

- This product is classified as a Class 4 Laser Product in IEC / JIS standards and a Class IV Laser Product in FDA regulations 21 CFR 1040.10. Never look at or touch the direct laser beam and its reflection.
- The laser used by this product generates infrared light that is invisible to the human eye. Use particular caution when the laser is operating.
- The following labels are attached to this product. Handle the product according to the instruction given on the warning labels. (Warning labels are not shown in the product photographs in this catalog.)

Recommended use of a dust collector

- Depending on the object being marked, harmful gasses or smoke that have a detrimental effect on the human body or the laser marker may be generating during marking. If your application falls under this description, use a dust collector.

* For more information, contact your sales representative.

● Dimensions (Unit: mm in)

Controller

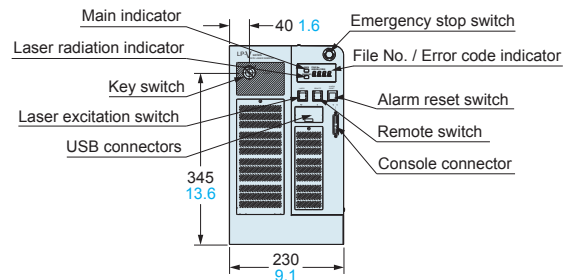
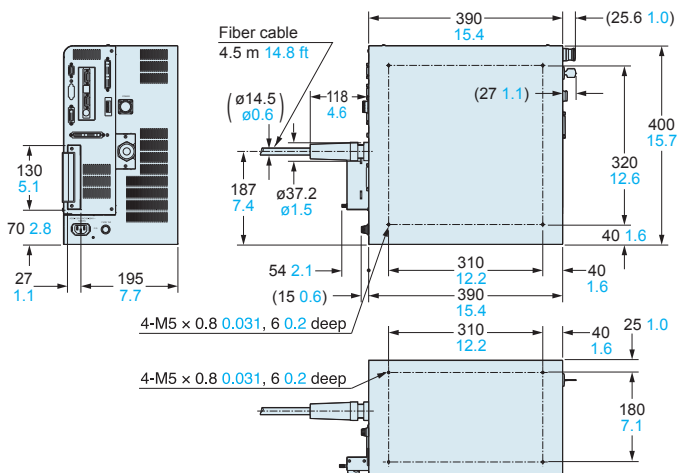

Head (LP-V10U)

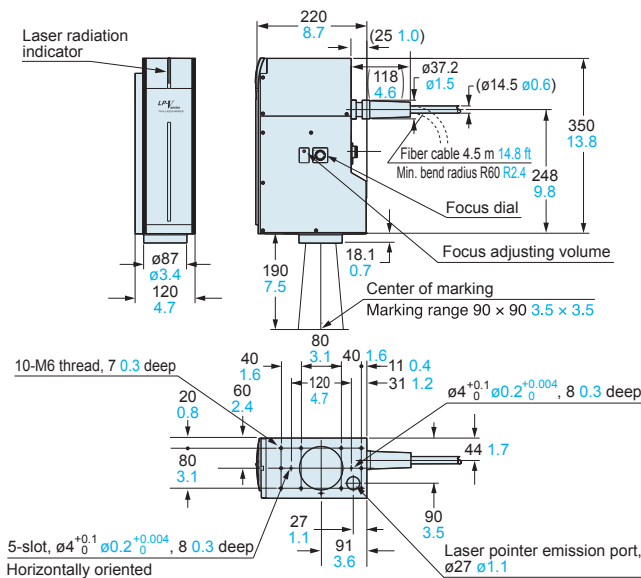

Head (LP-V15U)

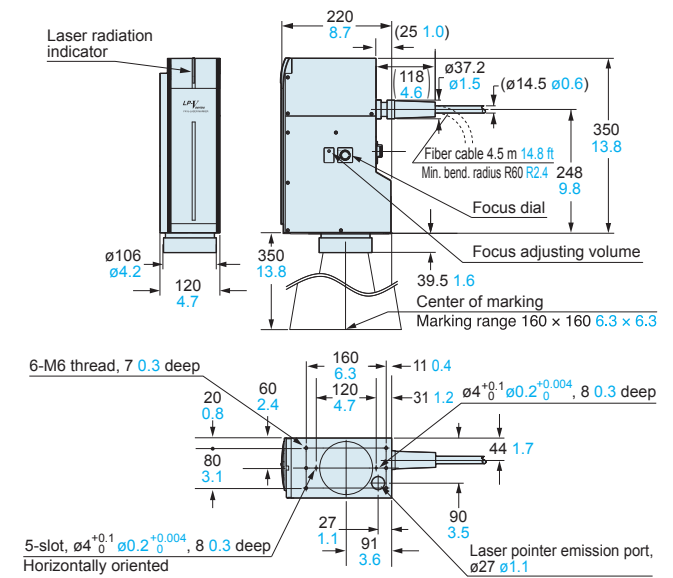

● Dimensions (Unit: mm in)

Head (LP-W052U)

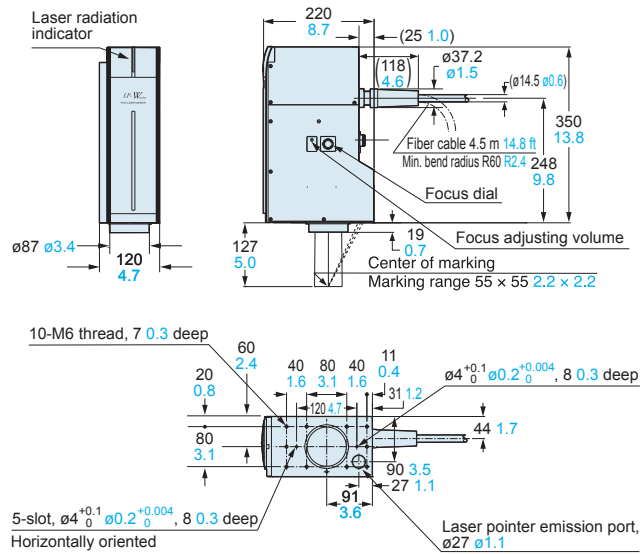

Console LP-ADP40 (Sold separately)

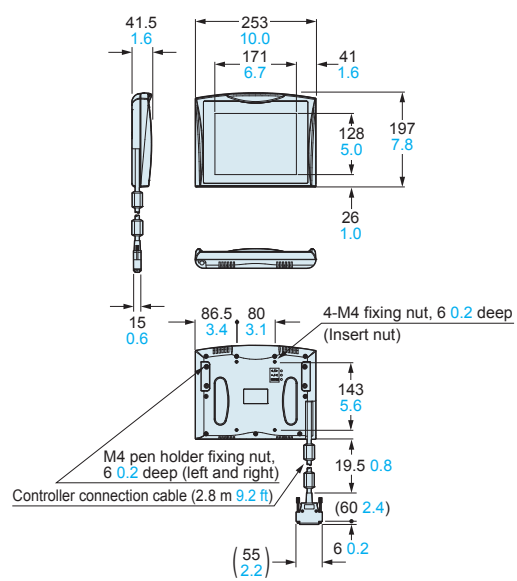

Please contact

Panasonic Electric Works SUNX Co., Ltd.

2431-1 Ushiyama-cho, Kasugai-shi, Aichi, 486-0901, Japan
 ■Telephone: +81-568-33-7211 ■Facsimile: +81-568-33-2631
 Overseas Marketing Department
 ■Telephone: +81-568-33-7861 ■Facsimile: +81-568-33-8591
panasonic-electric-works.net/sunx

Panasonic[®]

All Rights Reserved ©Panasonic Electric Works SUNX Co., Ltd. 2011